

Hall Ticket Number :

--	--	--	--	--	--	--	--	--	--

R-14

Code: 4GC13

B.Tech. I Year Supplementary Examinations May/June 2019

Engineering Chemistry

(Common to All Branches)

Max. Marks: 70

Time: 3 Hours

Answer *all five* units by choosing one question from each unit (5 x 14 = 70 Marks)

UNIT-I

1. a) What is hardness of water? Mention its units?
- b) Describe the desalination process by reverse osmosis with a neat sketch.

OR

2. a) Write a note on internal treatment?
- b) What is break point chlorination? State its significance?

UNIT-II

3. a) Differentiate between cathodic protection and anodic protection?
- b) what is the EMF Of the following cell at 25°C
Zn(s)/Zn⁺⁺(0.1M)//Cu⁺⁺(1.75M)/Cu(s). The standard emf of the cell is 1.1V.

OR

4. a) What is electrochemical corrosion? Explain electrochemical theory of corrosion.
- b) How is corrosion prevented by sacrificial anodic protection and cathodic protection? Explain.

UNIT-III

5. What are silicones? Give preparation, properties and applications of silicones.

OR

6. Describe the preparation, properties and uses of
(i) Bakelite (ii) nylon 6,6

UNIT-IV

7. Give an account of the different methods used for the synthesis of petrol

OR

8. A Sample was found to have the following percentage composition
C = 75%, H = 5.2%, O = 12.1%, N = 3.2%, ash = 4.5%.
 - (i) calculate the weight & volume of air required of combustion of 1 kg of coal
 - (ii) calculate the higher calorific value and lower calorific value of coal sample

UNIT-V

9. What is the composition of Portland cement? Explain how Portland cement is manufactured by wet process, with the help of chemical reactions involved in it.

OR

10. Write a short notes on
 - (a) Fire and flash points.
 - (b) Cloud and pour point.
 - (c) Aniline point

Code: 4G513

B.Tech. I Year Supplementary Examinations May / June 2019

Engineering Drawing

(Common to EEE, ECE, CSE and IT)

Max. Marks: 70

Time: 3 Hours

Answer all five units by choosing one question from each unit (5 x 14 = 70 Marks)

UNIT-I

1. The foci of an ellipse are 90mm apart and the minor axis is 65mm long. Draw the ellipse. Draw a tangent to it at a point on it 15mm from major axis.

OR

2. Draw a hypocycloid of a circle of 40mm dia. Which rolls inside another circle of 160mm dia. Draw a tangent to it at a point 65mm from the center of the directing circle?

UNIT-II

3. One end of a line 75mm long is 20mm above H.P. and 25mm in front of V.P. The line is inclined at 30° to H.P. and the top view makes an angle of 45° with XY. Draw the projections of the line and find its true inclination with V.P.

OR

4. A line AB is 75mm long. A is 50mm in front of V.P. and 15mm above H.P. B is 15mm in front of V.P. Top view of AB is 50mm long. Draw its projections and determine its inclinations with reference planes.

UNIT-III

5. A rectangular plane of size 60 mm x 30mm has its shorter side on the H.P and inclined at 30° to V.P. Draw the projections of the plane, if its surface is inclined at 45° to H.P.

OR

6. Draw the projections of a regular pentagon of 30mm side with its surface is making an angle of 30° with H.P. One of the sides of the pentagon is lying on the H.P and perpendicular to V.P.

UNIT-IV

7. Draw the projections of a cone of base 40mm and height 65 mm when it is lying on a point of the base on H.P, with its axis inclined at 30° to H.P and parallel to V.P.

OR

8. Draw the projections of a hexagonal prism of base 25mm side and axis 60mm long, when it is resting on one of its corners of the base on H.P. The axis of the solid is inclined at 45° to H.P.

UNIT-V

9. Draw the isometric view of a cylinder of base diameter 30mm and height is 70mm, when its axis is perpendicular to H.P.

OR

10. The Figure shows an object. Draw its (i) Front view (ii) Top view (iii) Side view. Assume all the dimensions are in 'mm'.

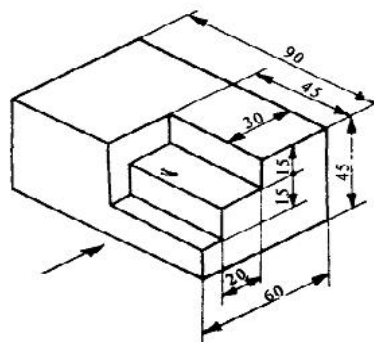

Hall Ticket Number :

--	--	--	--	--	--	--	--	--	--	--

R-14

Code: 4GC12

B.Tech. I Year Supplementary Examinations May 2019

Engineering Physics

(Common to All Branches)

Max. Marks: 70

Time: 3 Hours

Answer all five units by choosing one question from each unit (5 x 14 = 70 Marks)

UNIT-I

1. a) Explain the interference due to thin films and draw the conditions for constructive and destructive interference.
b) Distinguish between interference and diffraction of light.

OR

2. Distinguish between gas and solid state lasers with examples.

UNIT-II

3. a) Explain the terms
(i) Screw and edge dislocations (ii) Burger's vector.
b) For a simple cubic lattice find the ratios of interplanar separation $d_{111}:d_{110}:d_{100}$

OR

4. a) With neat diagrams and examples explain the seven crystal systems.
b) Derive Bragg's law.

UNIT-III

5. a) What are matter waves? Explain their properties.
b) State and explain de-Broglie's hypothesis of matter waves.

OR

6. Discuss with suitable mathematical expressions, the Kronog-Penney model for the energies of an electron in a metal.

UNIT-IV

7. a) Discuss with help of a neat diagram, the hysteresis loop observed in ferromagnetic material.
b) Classify the magnetic materials into soft and hard based on hysteresis loop.

OR

8. Describe different types of magnetic materials in terms of their spin dipole alignment and its temperature dependence with examples.

UNIT-V

9. Describe the basic principles of Nano materials causing the change in its properties.

OR

10. a) Prove that every super conducting material exhibit the diamagnetic property.
b) Explain DC and AC Josephson effects and mention I-V characteristics.

Code: 4GC14

B.Tech. I year Supplementary Examinations May / June 2019

Mathematics-I

(Common to All Branches)

Max. Marks: 70

Time: 3 Hours

Answer all five units by choosing one question from each unit (5 x 14 = 70 Marks)

UNIT-I

1. a) Solve $x \frac{dy}{dx} + y = \log x$
 b) Solve $y'' - y' - 2y = 3e^{2x}$, $y(0) = 0$, $y'(0) = -2$

OR

2. a) Find the orthogonal trajectories of the family of cardioids $r = a(1 - \cos \theta)$, where 'a' is the parameter.
 b) Solve $(D^2 - 1)y = x \sin x + e^x$

UNIT-II

3. a) Verify Lagrange's mean value theorem for $f(x) = x^3 - x^2 - 5x + 3$ in $[0, 4]$
 b) Find the minimum value of $x^2 + y^2 + z^2$ given that $xyz = a^3$

OR

4. a) Verify Rolle's theorem for the function $\log \left[\frac{x^2 + ab}{x(a+b)} \right]$ in $[a, b]$, $a > 0, b > 0$.
 b) If $x + y + z = u$, $y + z = uv$, $z = uvw$, then evaluate $\frac{\partial(x, y, z)}{\partial(u, v, w)}$

UNIT-III

5. a) Trace the curve $y^2(a - x) = x^3$ ($a > 0$)
 b) Evaluate $\int_0^5 \int_0^{x^2} x(x^2 + y^2) dx dy$

OR

6. a) Trace the curve $r = a(1 + \cos \theta)$
 b) Evaluate $\iint (x^2 + y^2) dx dy$ in the positive quadrant for which $x + y \leq 1$

UNIT-IV

7. a) Evaluate $L\{e^{2t} + 4t^3 - 2\sin 3t + 3\cos 3t\}$
 b) Find $L\{f(t)\}$, where $f(t)$ is a periodic function of period $2f$ and it is given by $f(t) = \begin{cases} \sin t, & 0 < t < f \\ 0, & f < t < 2f \end{cases}$

OR

8. a) Find the Laplace transform of $e^{-3t}(2\cos 5t - 3\sin 5t)$
 b) Find the inverse Laplace transform of $\log \left(\frac{s+3}{s+4} \right)$

UNIT-V

9. a) Find the angles between the surface $x^2 + y^2 + z^2 = 9$ and $z = x^2 + y^2 - 3$ at the point $(2, -1, 2)$
 b) If $\vec{f} = (5xy - 6x^2)\vec{i} + (2y - 4x)\vec{j}$, evaluate $\int_c \vec{f} \cdot d\vec{r}$ along the curve 'c' in xy -plane $y = x^3$ from $(1, 1)$ to $(2, 8)$.

OR

10. (i) If $\vec{f} = (x + 3y)\vec{i} + (y - 2z)\vec{j} + (x + pz)\vec{k}$ is solenoidal, find p.
 (ii) Find curl \vec{f} where $\vec{f} = \text{grad}(x^3 + y^3 + z^3 - 3xyz)$.

--	--	--	--	--	--	--	--	--	--

Code: 4G113

B.Tech. I Year Supplementary Examinations May / June 2019

Programming in C Introduction to Data Structures

(Common to CE, EEE, ME & ECE)

Max. Marks: 70

Time: 3 Hours

Answer all five units by choosing one question from each unit (5 x 14 = 70 Marks)

UNIT-I

1. a) What is Central Processing Unit (CPU) in a computer? Explain about various components and their functions of CPU.
- b) What is an integer constant, floating constant and character constant? Give valid examples.

OR

2. a) What are the steps involved in program development process? Explain.
- b) Describe the Structure of a C Program.

UNIT-II

3. a) Write a program to find the factorial of a given number
- b) Explain the following string handling functions with examples:
(i) strcpy() (ii) strcat() (iii) strrev() (iv) strlen

OR

4. a) What are the relational operators? Explain with examples.
- b) What is an array? Write a C program to accept elements into a one dimensional array.

UNIT-III

5. a) Explain dynamic memory allocation with examples
- b) What is a pointer? What are the features of pointers? Write a C program to print address of a variable

OR

6. a) What do you mean by functions? Give the structure of the functions and explain about the arguments and their return values.
- b) Write a c program to swap two numbers using call by value and call by reference.

UNIT-IV

7. a) Write C programs that use recursive functions to perform the linear searching operations for a Key value in a given list of integers
- b) What is a FILE? Explain the formatted input and output functions and give examples

OR

8. a) Write a program to copy content of existing file to another file.
- b) Write a C program to sort integer numbers using selection sort.

UNIT-V

9. Write a 'C' program to implement the stack operations using arrays.

OR

10. Write a C program to implement the operation of circular queue.
