

Hall Ticket Number :										
----------------------	--	--	--	--	--	--	--	--	--	--

<b>R-13</b>
-------------

**Code: 1GC13**

B.Tech. I Year Supplementary Examinations August 2021

**Engineering Chemistry**

( Common to All Branches )

Max. Marks: 70

Time: 3 Hours

Answer any **five** questions

All Questions carry equal marks (**14 Marks** each)

\*\*\*\*\*

1. a) Explain the process of a phosphate, carbonate and sodium aluminate conditioning of boiler feed water  
b) Give detailed procedure for the determination of dissolved oxygen in water.
2. a) What is meant by Specific Conductance and Equivalent conductance? Write their Units?  
b) Explain the composition, working and applications of Ni-Cd cell
3. a) Write a note on the mechanism of hydrogen evolution type of wet corrosion.  
b) Explain rusting of iron with the help of electrochemical theory of corrosion
4. a) What is vulcanization of rubber? Explain why natural rubber needs vulcanization. How is it carried out?  
b) Write a note on the classification of polymers with examples
5. a) What are explosives? How are they classified?  
b) What are the precautions to be taken during storage of explosives?
6. a) What is phase rule and explain the terms involved in it with suitable examples  
b) Define the term triple point? Discuss the significance of triple point in the phase diagram of water system.
7. a) Explain various steps involved in refining of petroleum  
b) Describe how synthetic petrol is synthesized from Bergius process
8. a) Describe the analysis of cement  
b) Write a note on the classification of refractories with examples.

\*\*\*

**Code: 1G513**

B.Tech. I Year Supplementary Examinations August 2021

**Engineering Drawing**  
( Common to EEE, ECE, CSE & IT )

Max. Marks: 70

Time: 3 Hours

Answer any **five** questions  
All Questions carry equal marks (**14 Marks** each)  
\*\*\*\*\*

1. Draw an ellipse when the distance of its focus from its directrix is equal to 50mm and eccentricity is  $2/3$ . Also draw a tangent and a normal to this ellipse at a point 70mm away from the directrix. 14M
2. Draw a cycloid for one complete revolution of a circle having a 50mm diameter. Draw a tangent and normal to the curve at a point distant 35mm above the base line. 14M
3. A line AB of 100mm length is inclined at an angle of  $30^\circ$  to HP and  $45^\circ$  to VP. The point A is 15 above HP and 25 in front of VP. Draw the projections of the line. 14M
4. A circular plate of 60mm diameter has a hexagonal hole of 20mm side, centrally punched. Draw the projections of the plate, resting on HP on a point with a surface inclined at  $30^\circ$  to HP. Any two parallel sides of the hexagonal hole are perpendicular to VP. Draw the projections of the plate. 14M
5. Draw the projections of a cylinder of base 30mm diameter and axis 50mm long when it is resting on HP on one of its base. 14M
6. Draw the isometric view of a square prism, with side of base 40mm and length of axis 70mm, when its axis is 1) vertical and 2) horizontal 14M
7. Draw the isometric view of 14M

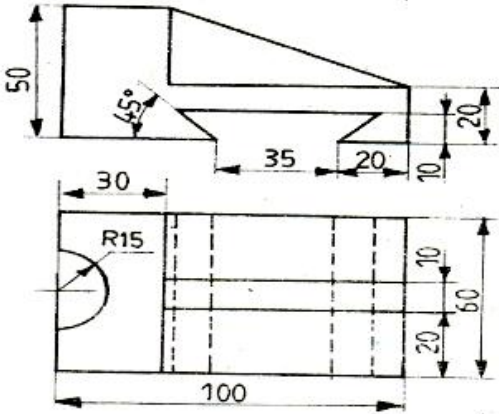

8. Draw the front view and top view of

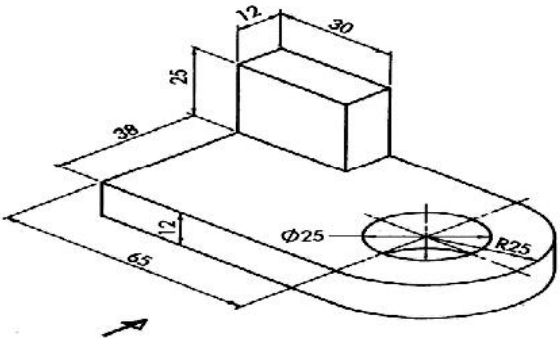

\*\*\*

Hall Ticket Number :

--	--	--	--	--	--	--	--	--	--

R-13

Code: 1GC14

B.Tech. I Year Supplementary Examinations August 2021

**Mathematics-I**

( Common to All Branches )

Max. Marks: 70

Time: 3 Hours

Answer any **five** questions

All Questions carry equal marks (**14 Marks** each)

\*\*\*\*\*

1. a) The rate at which bacteria multiply is proportional to the instantaneous number present. If the original number doubles in 2 hours, in how many hours will it be triple?  
b) Solve  $x \frac{dy}{dx} + y = x^3 y^6$ .
2. Solve  $\frac{d^2 y}{dx^2} - 2 \frac{dy}{dx} + y = x e^x \sin x$ .
3. a) Prove that  $\log(1 + e^x) = \log 2 + \frac{x}{2} + \frac{x^2}{8} - \frac{x^4}{192} + \dots$   
b) Find the maxima and minima of  $f(x) = x^3 + y^3 - 3axy$ .
4. a) Trace the curve  $r = a \sin 2\theta$   
b) Trace the curve  $x^3 + y^3 = 3axy$
5. Evaluate  $\int_0^1 \int_0^x e^y dx dy$
6. Find the Laplace transform of  $e^{-3t} (2 \cos 5t - 3 \sin 5t + 2t)$
7. Solve  $y^{11} - 3y^1 + 2y = e^{3t}$  when  $y(0) = 1, y^1(0) = 0$ .
8. Find  $\text{div } \vec{F}$  and  $\text{Curl } \vec{F}$  when  $\vec{F} = \text{grad}(x^3 + y^3 + z^3 - 3xyz)$ .

\*\*\*\*

Hall Ticket Number :										
----------------------	--	--	--	--	--	--	--	--	--	--

<b>R-13</b>
-------------

**Code : 1G111**

B.Tech. I Year Supplementary Examinations August 2021

**Programming in C and Data Structures**

( Common to CSE & IT)

**Max. Marks: 70**

**Time: 03 Hours**

Answer any five questions

All Questions carry equal marks (14 Marks each)

\*\*\*\*\*

1. a) Define the flow chart? Draw a flow chart for finding biggest of two numbers? 8M  
b) Write an algorithm to find the simple interest. 6M
2. a) Explain briefly the structure of 'c'? Write a program to find factorial of a number. 7M  
b) Write a program to check that the entered year is a leap year or not using any one of the control statement. 7M
3. a) Explain two-dimensional array within an example? 7M  
b) Write a program to accept n elements into a one dimensional array and display them. 7M
4. a) What is a pointer? Explain pointers in detail? 8M  
b) Write a program to swap the values of two elements using pointers? 6M
5. a) Write a program to read and display student details using a structure. 6M  
b) Write the syntax of the following file functions: (i) fopen() (ii) fclose() (iii) fread() (iv) fwrite() (v) rewind() (vi) fprintf() (vii) fscanf() (viii) feof(). 8M
6. a) Explain stack operations (Push and Pop) with an example? 7M  
b) Differentiate between Queue and Circular Queue. 7M
7. a) Explain breadth first search (BFS) algorithms with an example. 7M  
b) Explain Tree Traversal techniques with an example. 7M
8. a) Write and explain the algorithm for linear search with suitable example. 7M  
b) Explain the algorithm for bubble sort with a suitable example. 7M

\*\*\*