

Code: 7G512

I B.Tech. I Semester Regular Examinations December 2017

**Engineering Mechanics - Statics**

( Common to CE and ME )

Max. Marks: 70

Time: 3 Hours

Answer all five units by choosing one question from each unit ( 5 x 14 = 70 Marks )

\*\*\*\*\*

**UNIT-I**

1. Two identical rollers, each of weight  $Q = 445 \text{ N}$ , are supported by an inclined plane and a vertical wall as shown in Fig.1. Assuming smooth surfaces, find the reactions induced at the points of support A, B and C.

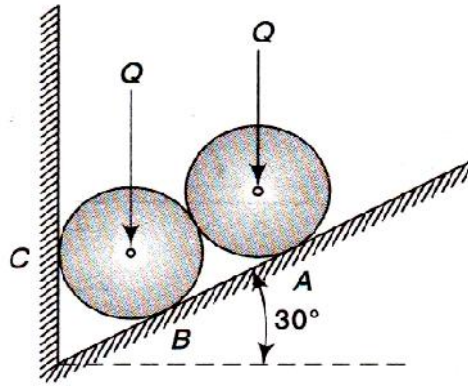

Fig.1

**OR**

2. In Fig.2, a force  $T$  acts along  $BE$  and a force  $P$  acts along  $AD$ . Assuming their force multipliers to  $T_m = 20 \text{ N/m}$  and  $P_m = 10 \text{ N/m}$ , find the force  $F$  to be applied at  $C$  to reduce their resultant to a couple. What is the resultant couple?

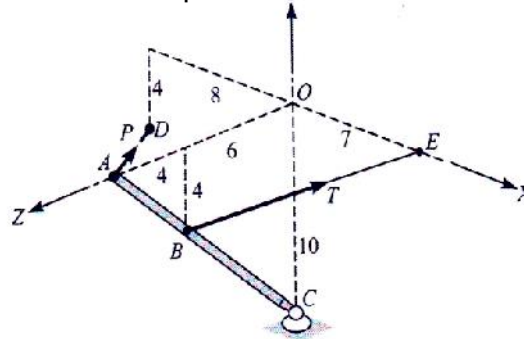

Fig.2

**UNIT-II**

3. Determine the forces in all the members of the truss shown in Fig.3 and indicate the magnitude and nature of the forces on the diagram of the truss. All inclined members are  $60^\circ$  to horizontal and length of each member is 2 m.

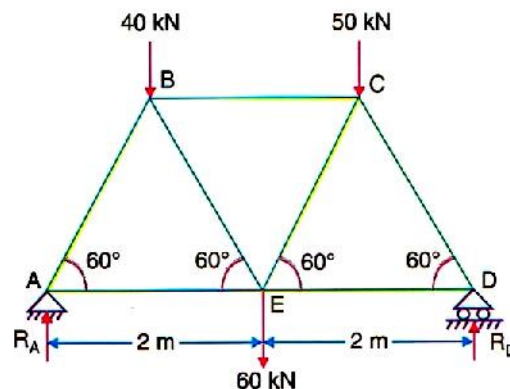

Fig.3

**OR**

4. A horizontal beam AB is hinged to a vertical wall at A and supported at its mid – point C by a tie rod CD as shown in Fig.4. Find the tension S in the tie rod and the reaction at A due to a vertical load P applied at B.

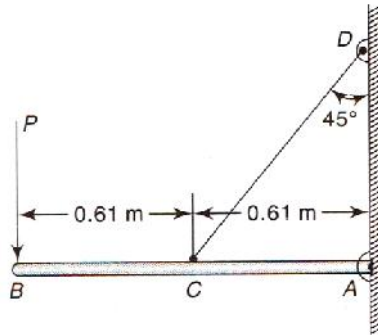

Fig.4

UNIT-III

5. In Fig.5, C is a stone block weighing 6KN. It is being raised slightly by means of two wooden wedges A and B with a force P on wedge B. The angle between the contacting surface of the wedge is  $5^\circ$ . If coefficient of friction is 0.3 for all surfaces, computing the value of P required to impend upward motion of the block C. Neglecting weight of the wedges.

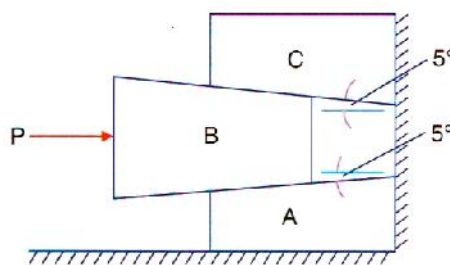

Fig.5

OR

6. What should be the value of  $\theta$  in Fig.6 that will make the motion of 200 N block down the plane to impend? The coefficient of friction for all contact surface is  $1/3$ .

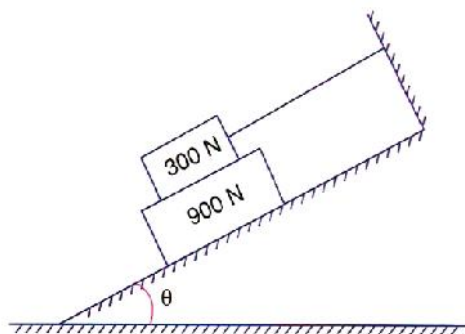
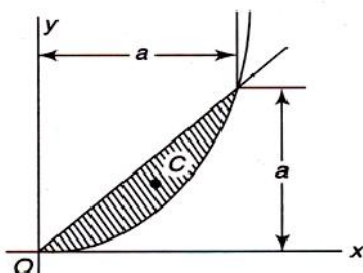

Fig.6

UNIT-IV

- 7 a) State Pappu's first and second theorems  
 b) Determine the coordinates  $x_c$  and  $y_c$  of the centroid C of the area between the parabola  $y = x^2/a$  and the straight line  $y = x$



OR

8. Locate the centroid of the shaded area shown in Figure

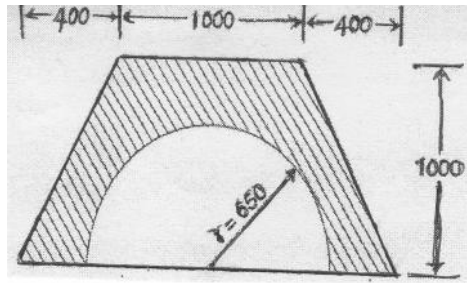

UNIT-V

9. a) State perpendicular axis theorem  
 b) Determine the moment of inertia of the area shown in Fig.9 with respect to its centroidal axes.

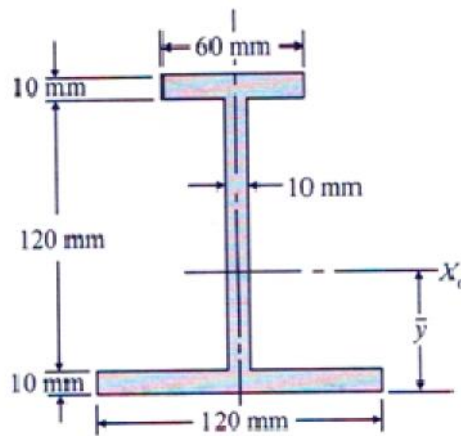

OR

- 10 a) What do you mean by mass moment of inertia?  
 b) Determine mass moment inertia with respect to centroidal axes for the rectangular plate and circular plate (Fig10).

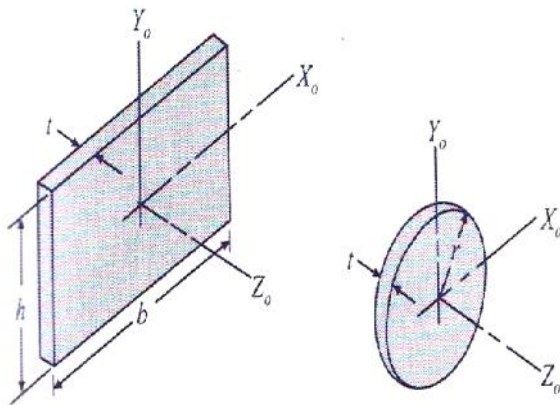

\*\*\*\*

**Code: 7GC12**

I B.Tech. I Semester Regular Examinations December 2017

**Engineering chemistry**  
( Common to CE, ME and CSE )

Max. Marks: 70

Time: 3 Hours

Answer *all five* units by choosing one question from each unit ( 5 x 14 = 70 Marks )

\*\*\*\*\*

**UNIT-I**

1. What is hardness of water? How do you classify and express hardness? Determine the total, temporary and permanent hardness of water by EDTA method. 14M

**OR**

2. a) Write a short notes on  
i) Break point chlorination 8M  
ii) Caustic embrittlement
- b) Explain the process of a phosphate ,carbonate and sodium aluminate conditioning of boiler feed water 6M

**UNIT-II**

3. a) Explain the construction and functioning of Galvanic Cell 7M  
b) i) Describe the sacrificial anodic protection in corrosion control. 4M  
ii) Define molar and equivalent conductance 3M

**OR**

4. a) Write short notes on concentration corrosion and galvanic corrosion 8M  
b) What are fuel cells? How does fuel cell differ from battery? List the merits and demerits of fuel cell. 6M

**UNIT-III**

5. a) Explain the differences between thermoplastics and thermosetting plastics with examples. 7M  
b) Why silicones are called inorganic polymers? Discuss the synthesis of linear chain silicones. 7M

**OR**

6. a) What is meant by condensation polymerization? Describe the preparation, properties and uses of Nylon-6,6 8M  
b) What is vulcanization of rubber? Explain the natural rubber needs vulcanization. How is it carried out? 6M

**UNIT-IV**

7. a) Write short note on octane number and cetane number. 6M  
b) Describe the following i) Natural gas ii) Bio gas 8M

**OR**

8. a) How do you determine the calorific value of solid fuel experimentally? 7M  
b) Evaluate GCV and NCV of coal sample from the following data: Weight of coal sample 0.73gms, weight of water in calorimeter 1500gms, water equivalent of calorimeter 470gms,  $T_1$  and  $T_2$  are  $25^\circ\text{C}$  and  $28^\circ\text{C}$  respectively. % of H in coal 2.5, latent heat of steam 587 cal/gm 7M

**UNIT-V**

9. a) Explain the setting and hardening of cement with suitable chemical reactions 7M  
b) Write the characteristics of good refractory material. 7M

**OR**

10. a) Describe any two of the following  
i) Porosity ii) Thermal spalling iii) Refractoriness 8M  
b) Write the functions of lubricant. Describe any one mechanism of lubrication 6M

\*\*\*

Code: 7G511

I B.Tech. I Semester Regular Examinations December 2017

**Engineering Graphics-I**

( Common to CE and ME )

Max. Marks: 70

Time: 3 Hours

Answer all five units by choosing one question from each unit ( 5 x 14 = 70 Marks )

\*\*\*\*\*

**UNIT-I**

1. Draw a rectangle having its sides 125 mm and 75 mm long. Inscribe two parabolas in it with their axes bisecting each other. 14M

**OR**

2. Two straight lines OA and OB make an angle of  $90^\circ$  between them. P is a point 40 mm from OA and 50 mm from OB. Draw a hyperbola through P, with OA and OB as asymptotes, marking at least ten points. 14M

**UNIT-II**

3. Draw a hypo-cycloid of a circle of 40 mm diameter, which rolls inside another circle of 160 mm diameter, for one revolution counter clockwise. Draw a tangent and normal to it at a point 65 mm from the center of the directing circle. 14M

**OR**

4. An inelastic string 145 mm long, has its one end attached to the circumference of a circular disc of 40 mm diameter. Draw the curve traced out by the other end of the string, when it is completely wound around the disc, keeping the string always tight. 14M

**UNIT-III**

5. a) A point P is 15 mm above the H.P. and 20 mm in front of the V.P. Another point Q is 25 mm behind the V.P. and 40 mm below the H.P. Draw projections of P and Q keeping the distance between their projectors equal to 90 mm. Draw straight lines joining (i) their top views and (ii) their front views. 7M

- b) A point P is 50 mm from both the reference planes. Draw its projections in all possible positions. 7M

**OR**

6. The front view of a line AB measures 65 mm and makes an angle of  $45^\circ$  with xy. A is in the H.P. and the V.T. of the line is 15 mm below the H.P. The line is inclined at  $30^\circ$  to the V.P. Draw the projections of AB and find its true length and inclination with the H.P. Also locate its H.T. 14M

**UNIT-IV**

7. Draw a rhombus of diagonals 100 mm and 60 mm long, with the longer diagonal horizontal. The figure is the top view of a square of 100 mm long diagonals, with a corner on the ground. Draw its front view and determine the angle which its surface makes with the ground. 14M

**OR**

8. A composite plate of negligible thickness is made-up of a rectangle 60 mm x 40 mm, and a semi-circle on its longer side. Draw its projections when the longer side is parallel to the H.P. and inclined at  $45^\circ$  to the V.P., the surface of the plate making  $30^\circ$  angle with the H.P. 14M

**UNIT-V**

9. An isosceles triangle PQR having the base PQ 50 mm long and altitude 75 mm has its corners P, Q and R 25 mm, 50 mm and 75 mm respectively above the ground. Draw its projections by auxiliary plane method. 14M

**OR**

10. An equilateral triangle ABC of sides 75 mm long has its side AB in the V.P. and inclined at  $60^\circ$  to the H.P. its plane makes an angle of  $45^\circ$  with the V.P. Draw its projections by auxiliary plane method. 14M

\*\*\*

Hall Ticket Number : 

--	--	--	--	--	--	--	--	--	--	--

**R-17**

**Code: 7GC14**

I B.Tech. I Semester Regular Examinations December 2017

**Engineering Mathematics-I**

( Common to all Branches )

Max. Marks: 70

Time: 3 Hours

Answer all five units by choosing one question from each unit ( 5 x 14 = 70 Marks )

\*\*\*\*\*

**UNIT-I**

1. a) Define rank of a matrix. Find the rank of the matrix  $A = \begin{bmatrix} 1 & 2 & 3 & 0 \\ 2 & 4 & 3 & 2 \\ 3 & 2 & 1 & 3 \\ 6 & 8 & 7 & 5 \end{bmatrix}$

b) Investigate for what values of } and ~ the simultaneous equations  $2x + 3y + 5z = 9; 7x + 3y - 2z = 8; 2x + 3y + }z = \sim,$  have (i) no solution (ii) a unique solution (iii) infinite number of solutions.

**OR**

2. a) Find the eigenvalues and eigenvectors of the matrix  $A = \begin{bmatrix} 2 & 2 & 1 \\ 1 & 3 & 1 \\ 1 & 2 & 2 \end{bmatrix}$

b) Use Cayley-Hamilton theorem for the matrix  $A = \begin{bmatrix} 2 & 1 & 1 \\ 0 & 1 & 0 \\ 1 & 1 & 2 \end{bmatrix}$  and express

$A^8 - 5A^7 + 7A^6 - 3A^5 + A^4 - 5A^3 + 8A^2 - 2A + I$  as a quadratic polynomial in  $A$ .

**UNIT-II**

3. a) If  $A = \begin{bmatrix} 8 & -8 & -2 \\ 4 & -3 & -2 \\ 3 & -4 & 1 \end{bmatrix}$  then find the matrix  $P$  which transforms the matrix  $A$  to a diagonal matrix.

b) If  $A = \begin{bmatrix} 0 & 1+2i \\ -1+2i & 0 \end{bmatrix}$  then show that  $(I - A)(I + A)^{-1}$  is a unitary matrix.

**OR**

4. Reduce the quadratic form  $6x^2 + 3y^2 + 3z^2 - 2yz + 4zx - 4xy$  in to a sum of squares. Also find the rank, index, signature and nature of the quadratic form.

## UNIT-III

5. a) Solve:  $(x+2y^3)\frac{dy}{dx} = y$ .
- b) Find the orthogonal trajectory of the family of curves  $r^n = a \sin n\theta$ .

OR

6. a) Solve:  $(y \log y) dx + (x - \log y) dy = 0$ .
- b) Uranium disintegrates at a rate proportional to the amount then present at any instant. If  $M_1$  and  $M_2$  grams of uranium are present at times  $T_1$  and  $T_2$  respectively, find the half-life of uranium.

## UNIT-IV

7. a) Solve:  $\frac{d^2y}{dx^2} - 4\frac{dy}{dx} + 4y = 8x^2 e^{2x} \sin 2x$ .
- b) Using the method of variation of parameters, solve:  $\frac{d^2y}{dx^2} - y = \frac{2}{1+e^x}$ .

OR

8. a) Solve:  $\frac{d^2y}{dx^2} + a^2y = \sec ax$ .
- b) A condenser of capacity  $C$  is discharged through the inductance  $L$  and a resistance  $R$  in series and the charge  $q$  at any time satisfies equation  $L\frac{d^2q}{dt^2} + R\frac{dq}{dt} + \frac{q}{C} = 0$ . Given that  $L=0.25$  henry,  $R=250$  ohms,  $C = 2 \times 10^{-6}$  farad and that when  $t = 0$ , the charge  $q$  is 0.002 coulomb, and the current  $\frac{dq}{dt} = 0$ . Obtain the value of  $q$  in terms of  $t$ .

## UNIT-V

9. a) If  $u = x^2 + y^2 + z^2$ ,  $v = xy + yz + zx$ ,  $w = x + y + z$ , find  $\frac{\partial(u, v, w)}{\partial(x, y, z)}$ .
- b) If  $u = u\left(\frac{y-x}{xy}, \frac{z-x}{xz}\right)$ , show that  $x^2 \frac{\partial u}{\partial x} + y^2 \frac{\partial u}{\partial y} + z^2 \frac{\partial u}{\partial z} = 0$ .
- OR
10. a) Find the extreme values of  $2(x^2 - y^2) - x^4 + y^4$ .
- b) Show that the rectangular solid of maximum volume that can be inscribed in a sphere is a cube.

\*\*\*

Hall Ticket Number :									
----------------------	--	--	--	--	--	--	--	--	--

<b>R-17</b>
-------------

**Code: 7G111**

I B.Tech. I Semester Regular Examinations December 2017

**Problem Solving Techniques and C Programming**

( Common to all Branches )

Max. Marks: 70

Time: 3 Hours

Answer all five units by choosing one question from each unit ( 5 x 14 = 70 Marks )

\*\*\*\*\*

<b>UNIT-I</b>
---------------

- 1. a) Define and explain the various steps involved in program development with example. 7M
- b) Describe the difference between Pseudo code and algorithm. Write Pseudo Code for finding factorial of a given number 7M

**OR**

- 2. a) Draw the Flow Chart for finding a number is prime or not. 7M
- b) Explain the Types and Categories of Programming Languages with example 7M

<b>UNIT-II</b>
----------------

- 3. a) State and explain Compiling and Execution process of a program 8M
- b) Differentiate between Keywords and Identifiers. 6M

**OR**

- 4. Illustrate the difference between Primary and Derived data types used in C with example. What is the importance of symbolic constant explain with example. 14M

<b>UNIT-III</b>
-----------------

- 5. i. Explain the conditional control statements with example.
- ii. Explain the code and what is the output of the following piece of code?  

```
main( )  
{  
int i=3;  
switch(i)  
{  
default : printf("0");  
case 1 : printf("1");  
break;  
case 2 : printf("2");  
break;  
case 3 : printf("3");  
break;  
}  
}
```

14M

**OR**



6. a) i. Differentiate between break and continue with an example.  
 ii. Write the output of the following code with explanation

```
while(1)
{
  if (printf ("%d", printf ("%d")))
  break;
  else
  continue;
}
```

10M

- b) Write a Program to find the topper of your class using "for" and "if ".

4M

<b>UNIT-IV</b>
----------------

7. a) Write a C Program to find Transpose of a Matrix. 10M  
 b) Write the functions to find Length of a String and Concatenate Two Strings 4M

**OR**

8. a) Write a C Program to Remove all Characters in a String Except Alphabets 10M  
 b) Explain the applications of array. 4M

<b>UNIT-V</b>
---------------

9. a) Write a C Program to Find G.C.D Using Recursion 8M  
 b) Explain the following key words with example.  
 i) Auto, ii) Register, iii) Static, iv) Extern. 6M

**OR**

10. a) Write a program to swap two numbers using call by reference and call by value. 7M  
 b) Why function is required to write a program, justify your answer with a suitable example. 7M

\*\*\*

Hall Ticket Number :

--	--	--	--	--	--	--	--	--	--	--

R-17

Code: 7GC11

I B.Tech. I Semester Regular Examinations December 2017

**Technical English & Professional Communication**

( Common to all Branches )

Max. Marks: 70

Time: 3 Hours

Answer all five units by choosing one question from each unit ( 5 x 14 = 70 Marks )

\*\*\*\*\*

**UNIT-I**

1. a) Explain the concept of 'Technology with a Human Face' and state why modern technology does not enrich man but empties him.
- b) Fill in the blanks in the following sentences using the hints given in brackets.
  - i. The only way to \_\_\_ women is to give them education.( a word with the prefix em-)
  - ii. Once the process of contamination of water begins, it is \_\_\_. ( a word with the prefix ir-)
  - iii. My friend speaks English \_\_\_\_\_ and correctly. ( freely, fluently)
  - iv. You have to \_\_\_\_\_ to many challenges in your life. ( Phrasal verb with face)
  - v. The man is moving \_\_\_\_\_ the building. ( at/ towards)

**OR**

2. What makes technical communication different from general communication?

**UNIT-II**

3. a) Explain with examples the two kinds of factors that cause the climate to change over long periods of time.
- b) Write a letter of application in response to an advertisement for the post of Assistant Civil Engineer in R & D Department.

**OR**

4. Describe in brief the five levels of communication.

**UNIT-III**

5. a) Discuss the two kinds of technologies currently used to generate solar power on a large scale.
- b) Complete the following sentences with appropriate words chosen from those in brackets:
  - i. To prove his points, he \_\_\_\_\_ an example. ( cited /sited)
  - ii. The workers raised a voice of \_\_\_ against the management. (dissent / descent)
  - iii. He is very \_\_\_\_\_ at dodging awkward questions. ( adept / adopt)
  - iv. Fruits makes a healthy \_\_\_ after lunch or dinner. ( desert / dessert)
  - v. The \_\_\_ at my work were fired. (personnel / personal)

**OR**

6. Explain the various functions of Non- verbal Communication.

**UNIT-IV**

7. a) Discuss some of the measures that are used to prevent soil erosion.
- b) Discuss in detail the Discriminative and Comprehensive listening.

**OR**

8. The management of your company proposes to establish a school near the factory site for the benefit of its staff. As Public Relations Officer you have been asked to study its feasibility and submit a report to the Personnel Manager, specially referring to the following: finance, teaching staff, library, games and sports, construction cost, etc.

**UNIT-V**

9. According to Swami Viveananda, what is the spirit in which the nature of work be done.

**OR**

10. List out the four communication styles and explain them briefly.

\*\*\*