

Hall Ticket Number :

--	--	--	--	--	--	--	--	--	--	--	--	--	--	--	--	--	--	--	--

**R-17**

**Code: 7GC14**

I B.Tech. I Semester Supplementary Examinations June 2024

**Engineering Mathematics-I**

(Common to All Branches)

Max. Marks: 70

Time: 3 Hours

Answer any five full questions by choosing one question from each unit (5x14 = 70 Marks)

\*\*\*\*\*

**UNIT-I**

1. Find the eigen values and eigen vectors of  $\begin{bmatrix} 5 & 4 \\ 1 & 2 \end{bmatrix}$

**OR**

2. Test for consistency and solve  $5x+3y+7z=4$ ,  $3x+26y+2z=9$ ,  $7x+2y+10z=5$

**UNIT-II**

3. Prove that the matrix  $\frac{1}{\sqrt{3}} \begin{bmatrix} 1 & 1+i \\ 1-i & -1 \end{bmatrix}$  is Unitary matrix.

**OR**

4. Reduce the matrix  $A = \begin{bmatrix} -1 & 2 & -2 \\ 1 & 2 & 1 \\ -1 & -1 & 0 \end{bmatrix}$  to the diagonal form.

**UNIT-III**

5. A body is kept in air with temperature  $25^{\circ}\text{C}$  cools from  $140^{\circ}\text{C}$  to  $80^{\circ}\text{C}$  in 20 minutes. Find the when the body cools down to  $35^{\circ}\text{C}$

**OR**

6. Solve  $x \frac{dy}{dx} + y = x^3 y^6$

**UNIT-IV**

7. Solve  $\frac{d^3y}{dx^3} - y = e^x + \sin 3x + 2$

**OR**

8. Solve  $(D^2 + 1)y = \sin x \sin 2x + e^x x^2$

**UNIT-V**

9. Verify Rolles theorem for  $f(x) = 2x^3 + x^2 - 4x - 2$  in  $[-\sqrt{2}, \sqrt{2}]$

**OR**

10. Verify lagrange's mean value theorem for  $f(x) = (x-1)(x-2)(x-3)$  in  $[0, 4]$

\*\*\*

Hall Ticket Number : 

--	--	--	--	--	--	--	--	--	--	--

**R-17**

**Code: 7GC13**

I B.Tech. I Semester Supplementary Examinations June 2024

**Engineering Physics**  
(Common to EEE & ECE)

Max. Marks: 70

Time: 3 Hours

Answer any five full questions by choosing one question from each unit (5x14 = 70 Marks )

\*\*\*\*\*

**UNIT-I**

1. What is interference? With a neat diagram, explain that the diameter of bright Newton's Ring is directly proportional to the square root of the odd number.

**OR**

2. What is optical fiber? Discuss briefly principle, construction and working of an optical fiber.

**UNIT-II**

3. Define the terms (i) Basis (ii) space lattice (iii) unit cell (iv) Coordination number (v) atomic radius (vi) Lattice parameters (vii) Packing fraction

**OR**

4. Explain the powder method of crystal structure analysis.

**UNIT-III**

5. Apply Schrodinger's wave equation to the case of particle confined in a box and show that the energies of particle are quantized.

**OR**

6. a) Explain Fermi- Dirac distribution function of electron.  
b) Describe the salient features of Kronig-Penny model.

**UNIT-IV**

7. Explain with a suitable diagram working of Hall effect and its uses.

**OR**

8. a) Elaborate Josephson effects and their applications.  
b) Describe with an appropriate diagram working of a P-N junction diode

**UNIT-V**

9. a) Derive an equation for magnetic moment of atom  
b) What are nanomaterials? Discuss the phenomena responsible for change in properties of nanomaterials.

**OR**

10. a) How optical and mechanical properties of nanomaterials varies with their size.  
b) Differentiate between Dia, para and ferro magnetic materials.

\*\*\*

Hall Ticket Number :

--	--	--	--	--	--	--	--	--	--	--

**R-17**

**Code: 7G511**

I B.Tech. I Semester Supplementary Examinations June 2024

**Problem Solving Techniques and C Programming**

(Common to All Branches)

Max. Marks: 70

Time: 3 Hours

Answer any five full questions by choosing one question from each unit (5x14 = 70 Marks )

\*\*\*\*\*

**UNIT-I**

1. a) What are the General Problem solving strategies? Discuss 7M
- b) Define Flowchart? Draw a flowchart to read three integers and find the biggest number. 7M

**OR**

2. a) Explain in detail about the computer environments. 7M
- b) Define Algorithm? What are the advantages of writing an Algorithm 7M

**UNIT-II**

3. a) Write and explain the structure of C Program 7M
- b) What is an identifier in C. Explain the rules of Identifiers. 7M

**OR**

4. a) What is Type Conversion? Illustrate type conversion with suitable examples. 7M
- b) Explain about the user defined data types in C language. 7M

**UNIT-III**

5. a) Write a C Program to find whether the given number is prime or not? 7M
- b) Write about the functioning of the jump statements, break and continue with suitable examples 7M

**OR**

6. What are Loop Control Statements in C. Explain them with suitable examples 14M

**UNIT-IV**

7. a) What is an Array? Explain how to declare one dimensional arrays with example. 7M
- b) Write a C Program to find whether the string is palindrome or not. 7M

**OR**

8. a) Write a C program to find the Average of all elements in the array. 4M
- b) What are the different String Library functions available in C? Explain them with example 10M

**UNIT-V**

9. a) What are type qualifiers in c language? Explain with suitable examples. 7M
- b) Write a C Program to find the factorial of a given number using recursion. 7M

**OR**

10. a) What is a function? What are the advantages of using functions in a program? 7M
- b) Explain function parameter passing techniques in C with suitable examples. 7M

\*\*\*

Hall Ticket Number :

--	--	--	--	--	--	--	--	--	--

R-19

Code: 19A312T

I B.Tech. I Semester Supplementary Examinations June 2024

**Engineering Graphics & Design**

(Common to EEE &amp; ECE)

Max. Marks: 70

Time: 3 Hours

Answer any five full questions by choosing one question from each unit (5x14 = 70 Marks )

\*\*\*\*\*

Marks CO BL

**UNIT-I**

1. The major and minor axes of an ellipse are 120mm and 80mm. Draw an ellipse by Concentric Circles method 14M CO1 L2

**OR**

2. Construct a regular Hexagon by General Method, given the length of its side is 50mm 14M CO1 L2

**UNIT-II**

3. Draw a hypocycloid of a circle of 40mm diameter, which rolls inside another circle of 160mm diameter, for one revolution counter clockwise. Draw a tangent & a normal to it at a point 65mm from the centre of the directing circle 14M CO2 L2

**OR**

4. Draw an involute for a circle of diameter 50 mm. Also draw a normal and tangent to the curve at a distance of 100mm from the center of circle 14M CO2 L2

**UNIT-III**

5. A 100mm long line is parallel to and 40mm above the H.P. Its two ends are 25mm and 50mm in front of the V.P respectively. Draw its projections and find its inclination with the V.P 14M CO3 L3

**OR**

6. A line AB, 65mm long, has its end A 20mm above the H.P. and 25mm in front of the V.P. The end B is 40mm above the H.P. and 65mm in front of the V.P. Draw the projections of AB and show its inclinations with the H.P. and the V.P 14M CO3 L3

**UNIT-IV**

7. Draw the projections of a regular hexagon of 25mm side, having one of its sides in the HP and inclined at  $60^\circ$  to the VP and its surface making an angle of  $45^\circ$  with the HP 14M CO4 L3

**OR**

8. A square ABCD of 40mm side has a corner on the HP and 20mm in front of the VP. All the sides of the squares are equally inclined to the HP and parallel to the VP. Draw its projections 14M CO4 L3

**UNIT-V**

9. Draw the projections of a right circular cylinder diameter of base 30mm and height 60mm resting on HP on its base, such that the axis is parallel to VP and inclined at  $30^\circ$  to HP 14M CO5 L3

**OR**

10. Convert the following isometric view to orthographic views

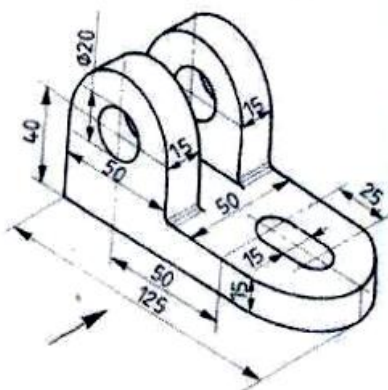

14M CO5 L3

\*\*\*