

Hall Ticket Number :

**R-23**

**Code: 23AHS13T**

B.Tech. I Semester Supplementary Examinations July 2024

**Engineering Chemistry**  
(Common to CE & ME)

Max. Marks: 70

Time: 3 Hours

\*\*\*\*\*

- Note: 1. Question Paper consists of two parts (**Part-A** and **Part-B**)  
2. In Part-A, each question carries **Two marks**.  
3. Answer **ALL** the questions in **Part-A** and **Part-B**

**PART-A**

( **Compulsory question** )

- |  |     |    |
|--|-----|----|
| 1. Answer <b>all</b> the following short answer questions ( 10 X 2 = 20M )       | CO  | BL |
| a) Hardness is expressed in terms of CaCO <sub>3</sub> equivalents? Give reason. | CO1 | L3 |
| b) Specify the requirements for portable water?                                  | CO1 | L1 |
| c) Differentiate primary and secondary batteries with examples.                  | CO2 | L2 |
| d) Enumerate the effects of corrosion.   | CO2 | L1 |
| e) Describe the polymerization involved in thermosetting plastics.               | CO3 | L2 |
| f) Define Gross calorific value and Net calorific value?                         | CO3 | L1 |
| g) Name three fibers used for preparing composites.                              | CO4 | L1 |
| h) Antioxidants are added to hydrocarbon oils. Justify with an example.          | CO4 | L3 |
| i) What is an adsorption isotherm?   | CO5 | L1 |
| j) Write BET equation  | CO5 | L1 |

**PART-B**

Answer **five** questions by choosing one question from each unit ( 5 x 10 = 50 Marks )

Marks CO BL

**UNIT-I**

- |  |     |     |    |
|--|-----|-----|----|
| 2. Define scales and sludges? How are they formed? Give their disadvantages and removal methods. | 10M | CO1 | L2 |
|--|-----|-----|----|

**OR**

- |  |    |     |    |
|--|----|-----|----|
| 3. a) Describe ion exchange process for demineralization of water. | 5M | CO1 | L2 |
| b) What is the principle of Electrodialysis                        | 5M | CO1 | L1 |

**UNIT-II**

- |   |     |     |    |
|---|-----|-----|----|
| 4. Define fuel cell. Explain the working principle of Hydrogen-Oxygen fuel cell with the reactions. | 10M | CO2 | L2 |
|---|-----|-----|----|

**OR**

- |   |     |     |    |
|---|-----|-----|----|
| 5. Explain the mechanism involved in the rusting of iron with the help of wet corrosion theory. | 10M | CO2 | L1 |
|---|-----|-----|----|

**UNIT-III**

6. a) Differentiate thermoplastic and thermosetting polymers 5M CO3 L3  
 b) Explain the preparation and uses of Bakelite 5M CO3 L2

**OR**

7. Explain in detail how is coal analyzed by proximate analysis method and give its significance. 10M CO3 L2

**UNIT-IV**

8. Explain the following properties of lubricants and give their significance a) Cloud point b) Flash point c) Fire point 10M CO4 L2

**OR**

9. a) Give the classification of refractories with suitable examples. 5M CO4 L1  
 b) Explain in detail about setting and hardening of Portland cement. 5M CO4 L2

**UNIT-V**

10. Synthesis any one of the nanoparticles by using chemical method 10M CO5 L4

**OR**

11. a) How do you stabilize colloids and nanomaterials 5M CO5 L1  
 b) List out the applications of nanomaterials in medicine 5M CO5 L1

\*\*\* End \*\*\*

Hall Ticket Number :

--	--	--	--	--	--	--	--	--	--	--

**R-23**

**Code: 23A0312T**

B.Tech. I Semester Supplementary Examinations July 2024

## **Engineering Graphics**

(Common to All Branches)

Max. Marks: 70

Time: 3 Hours

\*\*\*\*\*

Answer *five* questions by choosing one question from each unit ( 5 x 14 = 70 Marks )

Marks CO BL

### **UNIT-I**

1. Construct a parabola with the distance of the focus from the directrix as 50mm. Also draw normal and tangent to the curve, at a point 40mm from the directrix. 14M 1 2

**OR**

2. Construct a scale to be used with a map, the scale of which is 1 cm = 500 m. The maximum length to be read is 5 km. Mark on the scale, a distance of 3.85 km. 14M 1 3

### **UNIT-II**

3. A point A is 20 mm above the HP and 50mm in front of the VP. Another point B is 40mm below the HP and 15 mm behind the VP. The distance between the projectors of the points, measured parallel to xy, is 75mm. Draw the projections of the points. Draw lines joining their FVs and TVs. 14M 2 3

**OR**

4. The mid point of a straight line AB is 60mm above HP and 50mm in front of VP. The line measures 80mm long and inclined at 30° to HP and 45° to VP. Draw its projections. 14M 2 3

### **UNIT-III**

5. Draw the projections of a circle of 5 cm diameter, having its plane vertical and inclined at 30° to the VP. Its center is 3 cm above the HP and 2 cm in front of the VP 14M 3 3

**OR**

6. A triangular prism of base 30 mm side and axis 50 mm long, is resting on HP on one of its bases, with a face perpendicular to VP. Draw the projections of the solid. 14M 3 3

### **UNIT-IV**

7. A hexagonal prism of side of base 30 mm and length of axis 75 mm, is resting on a corner of its base on HP, with the longer edge containing that corner, inclined to HP at 30°. It is cut by a section plane parallel to HP and passing through the mid-point of the axis. Draw the front and sectional top views of the solid. 14M 4 4

OR

8. A hexagonal prism of side of base 20 mm and length of axis 50 mm is kept on the ground on its base such that two opposite sides of the base are parallel to the VP. It is cut by an AIP inclined at  $45^\circ$  to the HP and passing through one of the top corners of the prism. Draw the development of the cut prism.

14M 4 4

**UNIT-V**

9. Draw three views of the block shown pictorially in figure 1 according to first angle projection.

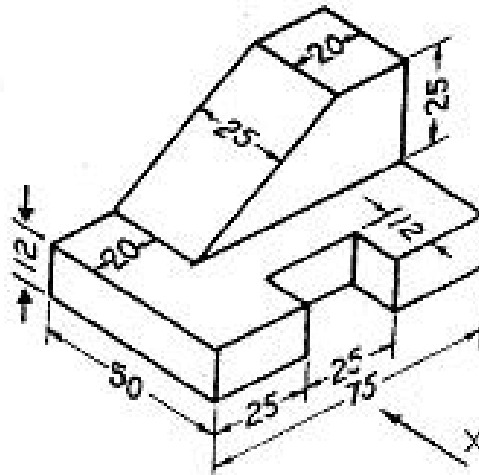

Figure 1

14M 5 4

OR

10. Draw the isometric view of the object shown in figure 2.

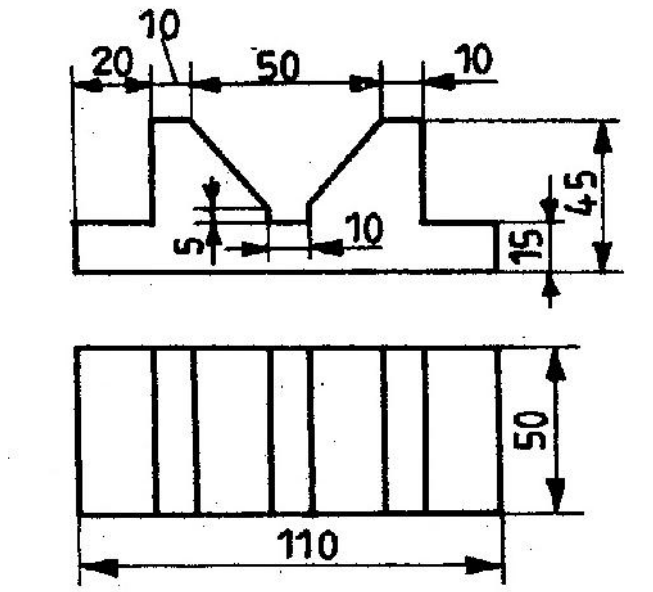

Figure 2

14M 5 4

\*\*\* End \*\*\*

Hall Ticket Number :

R-23

Code: 23A0511T

B.Tech. I Semester Supplementary Examinations July 2024

## Introduction to Programming

(Common to All Branches)

Max. Marks: 70

Time: 3 Hours

\*\*\*\*\*

- Note: 1. Question Paper consists of two parts (**Part-A** and **Part-B**)  
2. In Part-A, each question carries **Two marks**.  
3. Answer **ALL** the questions in **Part-A** and **Part-B**

### PART-A

( Compulsory question )

1. Answer **all** the following short answer questions ( 10 X 2 = 20M )
- |   | CO | BL |
|---|----|----|
| a) List different types of memories in computer systems.                                | 1  | 1  |
| b) Write the properties of an algorithm.  | 1  | 1  |
| c) List the control structures in C.  | 2  | 1  |
| d) Compare the difference between entry-controlled and exit-controlled statements       | 2  | 1  |
| e) Define array. Write the syntax for the declaration of initialization of the 2D array | 3  | 1  |
| f) Explain various parameter passing methods in C.                                      | 3  | 1  |
| g) Compare the differences between arrays and structures.                               | 4  | 1  |
| h) List the functions used for dynamic memory allocation in C.                          | 4  | 1  |
| i) Explain various text file opening modes  | 5  | 1  |
| j) Write the purpose of fseek() with example  | 5  | 1  |

### PART-B

Answer *five* questions by choosing one question from each unit ( 5 x 10 = 50 Marks )

Marks CO BL

#### UNIT-I

2. a) Explain in detail about computer hardware and software. 5M 1 1  
b) Write the pseudo-code for the conversion of temperature from Fahrenheit to Celsius 5M 1 1

OR

3. a) Explain in detail about data types in C 5M 1 2  
b) Write algorithm and draw flowchart for finding the greatest number among three numbers. 5M 1 2

#### UNIT-II

4. a) Write a C program to print first n lines of Floyd's Triangle.  
1  
2 3  
4 5 6  
7 8 9 10 5M 2 2  
b) Demonstrate the name of the day for the given week number using switch-case execution. 5M 2 2

**OR**

5. a) Write a program in C to find the prime numbers within a range of numbers. 5M 2 2  
 b) Explain about different loop control statements in C 5M 2 2

**UNIT-III**

6. a) Explain the following functions string handling functions.  
 i. strcmp() ii. strrev() 5M 3 2  
 b) Write C program to find the largest and smallest number among a list of integers. 5M 3 2

**OR**

7. a) Find an element in the given list along with position. 5M 3 2  
 b) Write C program to find the transpose of a matrix. 5M 3 2

Example

Given matrix

1 2 3  
 4 5 6

Transpose of the matrix:

1 4  
 2 5  
 3 6

**UNIT-IV**

8. a) Differentiate structures and unions. 5M 4 2  
 b) Explain the meaning and purpose of the following:  
 i. struct keyword ii. typedef keyword iii. sizeof operator 5M 4 2

**OR**

9. a) Write a C program to read and print the book details using structures. 5M 4 2  
 b) Define a pointer. How to initialize and declare pointer variable? Write a C program to find the sum of array element values using a pointer. 5M 4 2

**UNIT-V**

10. a) Demonstrate the user defined function (single function) to perform all arithmetic operations. 5M 5 2  
 b) Demonstrate the following functions through a sample program that reads a file "test.txt".  
 i. ftell() ii. fseek() iii. rewind() 5M 5 2

**OR**

11. a) Write the syntax of the following file I/O functions and Explain every option in each function with suitable example  
 i. fopen() ii. fclose() iii. fread() iv. fwrite() 6M 5 2  
 b) Explain about recursive function with an example. 4M 5 2

\*\*\* End \*\*\*

Code: 23AHS11T

B.Tech. I Semester Supplementary Examinations July 2024

**Linear Algebra and Calculus**

(Common to All Branches)

Max. Marks: 70

Time: 3 Hours

\*\*\*\*\*

- Note: 1. Question Paper consists of two parts (**Part-A** and **Part-B**)  
 2. In Part-A, each question carries **Two marks**.  
 3. Answer **ALL** the questions in **Part-A** and **Part-B**

**PART-A**

(Compulsory question)

1. Answer **all** the following short answer questions (10 X 2 = 20M) CO BL
- a) Define Echelon form of a matrix. What is the rank of a matrix which is in Echelon form? CO1 L1
- b) How do you find the inverse of a matrix by Gauss-Jordan method? CO1 L1
- c) Show that the Eigen values of a triangular matrix are the just diagonal elements. CO2 L2
- d) Write the real symmetric matrix corresponding to the quadratic form  $2(xy - yz + zx)$ . CO2 L1
- e) State Lagrange's mean value theorem. CO3 L1
- f) State Taylor's theorem with Lagrange's form of remainder. CO3 L1
- g) If  $f(x, y) = x^2 y \sin(xy) - xy^2 \cos(xy)$  find  $\frac{\partial f}{\partial x}$  and  $\frac{\partial f}{\partial y}$ . CO4 L2
- h) Write the properties of Jacobian. CO4 L1
- i) Evaluate  $\int_1^2 \int_1^3 xy^2 dx dy$ . CO5 L2
- Evaluate  $\int_0^a \int_0^x \int_0^y (x + y + z) dz dy dx$ .
- j) CO5 L2

**PART-B**

Answer five questions by choosing one question from each unit (5 x 10 = 50 Marks)

Marks CO BL

**UNIT-I**

2. a) Solve the following system of equations by Gauss elimination method

$$x_1 - x_2 + x_3 + x_4 = 2, \quad x_1 + x_2 - x_3 + x_4 = -4,$$

$$x_1 + x_2 + x_3 - x_4 = 4, \quad x_1 + x_2 + x_3 + x_4 = 0.$$

6M CO1 L3

- b) Solve the equations

$$x + 2y + 3z = 0, \quad 3x + 4y + 4z = 0, \quad 7x + 10y + 12z = 0$$

4M CO1 L3

**OR**

3. Solve the following equations using Gauss Seidal iteration method correct up to four decimal places.

$$10x + 2y + z = 9, \quad x + 10y - z = -22, \quad -2x + 3y + 10z = 22.$$

10M CO1 L3

<b>UNIT-II</b>
----------------

4. Find the characteristic equation of the matrix

$$A = \begin{bmatrix} 2 & 1 & 1 \\ 0 & 1 & 0 \\ 1 & 1 & 2 \end{bmatrix} \text{ and hence compute } A^{-1}.$$

Also find the matrix represented by

$$A^8 - 5A^7 + 7A^6 - 3A^5 + A^4 - 5A^3 + 8A^2 - 2A + I.$$

10M CO2 L3

**OR**

5. Reduce the following quadratic form

$$3x_1^2 + 3x_2^2 + 3x_3^2 + 2x_1x_2 + 2x_1x_3 - 2x_2x_3$$

into canonical form or sum of squares through orthogonal reduction and hence find the nature.

10M CO2 L3

<b>UNIT-I</b>
---------------

6. a) Verify Rolle's theorem for  $f(x) = \frac{\sin x}{e^x}$  in  $(0, f)$

5M CO3 L3

- b) Verify the result of Cauchy's mean value theorem for the

functions  $\log_e^x$  and  $\frac{1}{x}$  in  $[1, e]$ .

5M CO3 L3

**OR**

7. Verify Maclaurin's theorem for  $f(x) = (1-x)^{\frac{5}{2}}$  with Lagrange's form of remainder up to three terms when  $x=1$ .

10M CO3 L3

<b>UNIT-I</b>
---------------

8. If  $u = \log(x^3 + y^3 + z^3 - 3xyz)$  show that

$$\left( \frac{\partial}{\partial x} + \frac{\partial}{\partial y} + \frac{\partial}{\partial z} \right)^2 u = \frac{-9}{(x+y+z)^2}$$

10M CO4 L2

**OR**

9. Examine the following functions for maxima and minima

$$f(x, y) = x^4 + y^4 - 2x^2 + 4xy - 2y^2.$$

10M CO4 L2

<b>UNIT-I</b>
---------------

10. a) Evaluate  $\int_0^a \int_0^{\sqrt{a^2-y^2}} \sqrt{a^2-x^2-y^2} dx dy$ .

5M CO5 L3

- b) By changing into polar coordinates, evaluate

$$\int_0^\infty \int_0^\infty e^{-(x^2+y^2)} dx dy$$

5M CO5 L4

**OR**

11. Evaluate

$$\int_1^e \int_1^{\log y} \int_1^{e^x} \log z dz dx dy.$$

10M CO5 L3

\*\*\* End \*\*\*



Hall Ticket Number :												
----------------------	--	--	--	--	--	--	--	--	--	--	--	--

<b>R-23</b>
-------------

**Code: 23AHS12T**

B.Tech. I Semester Supplementary Examinations July 2024

**Communicative English**

(Common to CE, ME, CSE, CSE(DS) and AI&ML)

Max. Marks: 70

Time: 3 Hours

\*\*\*\*\*

- Note: 1. Question Paper consists of two parts (**Part-A** and **Part-B**)  
 2. In Part-A, each question carries **Two marks**.  
 3. Answer **ALL** the questions in **Part-A** and **Part-B**

**PART-A**

**( Compulsory question )**

- |  |    |    |
|--|----|----|
| 1. Answer <b>all</b> the questions (10 X 2 = 20M )   | CO | BL |
| a) Defend the way Jim and Della celebrate Christmas.   | 1  | L5 |
| b) Write two synonyms for each of the following words:<br>i) Perspective    ii) Harmonious   | 1  | L2 |
| c) Establish the superiority of the 'brook' over human beings.   | 2  | L5 |
| d) What is Sequencing?   | 2  | L2 |
| e) Evaluate the way a degree in arts helps Elon Musk.  | 3  | L5 |
| f) Write three effective steps for 'note-making'.  | 3  | L2 |
| g) According to the National Peace Council, what are the objections to traditional children's toys like soldiers and guns?                                       | 4  | L2 |
| h) Change the following sentences into direct speech.<br>i) He asked me whether I played Cards.<br>ii) She said that they went out for long walks every morning. | 4  | L3 |
| i) How can engaging in introspective dialogue help manage stress?  | 5  | L2 |
| j) Discuss any two strategies for Effective Reading Comprehension.   | 5  | L2 |

**PART-B**

Answer **five** questions by choosing one question from each unit (5 x 10 = 50 Marks)

Marks    CO    BL

<b>UNIT-I</b>
---------------

- |  |     |   |    |
|--|-----|---|----|
| 2. Examine the way O. Henry handles the surprise ending in his short story "The Gift of Magi". | 12M | 1 | L3 |
|--|-----|---|----|

**OR**

- |   |    |   |    |
|---|----|---|----|
| 3. a) Read the word that is underlined and try to identify the root word along with any prefix/suffix that is attached to it.<br>i) I stood on a balcony <u>overlooking</u> the park.<br>ii) Tata motors <u>manufactures</u> cars.<br>iii) He <u>contradicts</u> everything she says.<br>iv) Vaishnavi is always <u>methodical</u> in her work.<br>v) Don't be <u>Childish</u> !<br>vi) I am reading a <u>biography</u> . | 6M | 1 | L3 |
|---|----|---|----|

- b) Fill in the blanks with the antonym of the words underlined.
- He was wearing two different colour socks but at least his shoes were the \_\_\_\_
  - Please fill the dish washer and \_\_\_\_\_ the trash.
  - She was optimistic about attending college, but \_\_\_\_\_ about paying for it.
  - Progress is the antidote to \_\_\_\_\_
  - When it's cold and wet outside, it's so nice to be \_\_\_\_ and \_\_\_\_\_ inside. 6M 1 L3

**UNIT-II**

4. Summarize the book's narration of its journey into an essay with an emphasis on its destination, the brimming river. 12M 2 L2

**OR**

5. a) Fill in the blanks with a, an or the wherever necessary.
- I met \_\_\_\_\_ old friend at \_\_\_\_\_ party last night.
  - She is \_\_\_\_\_ expert in economics.
  - There is \_\_\_\_\_ magazine on \_\_\_\_\_ table in my room.
  - \_\_\_\_\_ education is essential for personal growth. 6M 2 L3
- b) Fill in the blanks with suitable prepositions:
- The house is \_\_\_\_\_ the park \_\_\_\_\_ the right \_\_\_\_\_ the school.
  - The guests are coming \_\_\_\_\_ six O' clock \_\_\_\_\_ the evening \_\_\_\_\_ Thursday. 6M 2 L3

**UNIT-III**

6. Write an essay on Elon Musk's success story. 12M 3 L2

**OR**

7. a) Correct the following sentences.
- I visited the gallery last night.
  - Neither the boy nor the girl are in the class.
  - Everyone want to succeed.
  - I have been learning French since three months.
  - If it rains I don't come to college.
  - When I entered the room, the students left the class. 6M 3 L4
- b) Form six compound words for each of the following combinations
- Verb + Noun
  - Adverb+ Adjective 6M 3 L4

**UNIT-IV**

8. In the context of "The Toys of Peace", what are potential implications of trying to completely eliminate violent play and imagery from children's lives. Discuss the balance between promoting peace and acknowledging children's innate instincts. 12M 4 L2

**OR**

9. Write a formal letter to a Professor stating a valid reason, and requesting an extension of deadline to submit an assignment. 12M 4 L2

**UNIT-V**

10. Do you think that intrapersonal communication is a crucial factor often overlooked in college life? What are some possible reasons for its being overlooked, and what impact could this have on your personal growth and leadership development? 12M 5 L5

**OR**

11. Formulate an expository essay on "Social Media: A curse or boon." 12M 5 L4

\*\*\* End \*\*\*