

Hall Ticket Number :										
----------------------	--	--	--	--	--	--	--	--	--	--

<b>R-19</b>
-------------

**Code: 19AC21T**

I B.Tech. II Semester Regular Examinations Nov/Dec 2020

**Differential Equations and Vector Calculus**

( Common to All Branches )

Max. Marks: 70

Time: 3 Hours

Answer any five questions from the following ( 5 x 14 = 70 Marks )

\*\*\*\*\*

	Marks	CO	Blooms Level
1. a) Solve $\frac{d^2y}{dx^2} + 16y = x \sin 3x$	7M	CO1	
b) Solve $y'' - 2y' + 2y = x + e^x \cos x$	7M	CO1	
2. Using method of variation of parameters, solve $y'' - 2y' + y = e^x \log x$	14M	CO1	
3. Solve $x^2 \frac{d^2y}{dx^2} + x \frac{dy}{dx} + y = \log x \sin(\log x)$	14M	CO2	
4. Solve $(2x - 1)^2 \frac{d^2y}{dx^2} + (2x - 1) \frac{dy}{dx} - 2y = 8x^2 - 2x + 3$	14M	CO2	
5. Solve $(p^2 + q^2)y = qz$ by Charpit's method.	14M	CO3	
6. a) Find the directional derivative of $f(x, y, z) = xy^3 + yz^3$ at the point (2, -1, 1) in the direction of the vector $\bar{i} + 2\bar{j} + 2\bar{k}$ .	7M	CO4	
b) Prove that $\text{div}(r^n \bar{r}) = (n + 3)r^n$	7M	CO4	
7. a) If $\bar{f} = \text{grad}[x^3y + y^3z + z^3x - x^2y^2z^2]$ then find $\text{div}\bar{f}$ and $\text{curl}\bar{f}$ .	7M	CO4	
b) If $\bar{F} = (5xy - 6x^2)\bar{i} + (2y - 4x)\bar{j}$ , evaluate $\int_C \bar{F} \cdot d\bar{r}$ along the curve C in the xy-plane, $y = x^3$ from the point (1, 1) to (2, 8).	7M	CO4	
8. Verify Green's theorem for $\int_C [(3x - 8y^2)dx + (4y - 6xy)dy]$ where c is the boundary of the region bounded by $x = 0$ , $y = 0$ and $x + y = 1$ .	14M	CO5	

\*\*\*\*\*

**Code: 19A421T**

I B.Tech. II Semester Regular Examinations Nov/Dec 2020

**Electronic Devices and Circuits**

( Common to EEE &amp; ECE )

Max. Marks: 70

Time: 3 Hours

Answer any five questions from the following ( 5 x 14 = 70 Marks )

\*\*\*\*\*

- |  | Marks | CO  | Blooms Level |
|--|-------|-----|--------------|
| 1. a) <b>Determine</b> the significance of operating point, DC and AC load lines to ensure active region operation of a BJT in CE amplifier Apply?   | 7M    | CO1 | L2           |
| b) <b>Design</b> a collector to base bias circuit using silicon transistor to achieve a stability factor of 20, with the following specifications: $V_{CC} = 16V$ , $V_{BE} = 0.7V$ , $V_{CEQ} = 8V$ , $I_{CQ} = 4mA$ & $\beta = 50$ ? | 7M    | CO1 | L3           |
| 2. a) <b>Compare</b> enhancement and depletion modes of a MOSFET with the help of its characteristics and construction?  | 8M    | CO2 | L5           |
| b) Data sheet for a JFET indicates that $I_{DS} = 10mA$ and $V_{GS(off)} = -4V$ . <b>Determine</b> the drain current for $V_{GS} = 0V, -1V$ and $-4V$ .  | 6M    | CO2 | L3           |
| 3. a) <b>List</b> any four merits of MOSFET to show that they are more suitable than JFETS in Integrated circuits?   | 6M    | CO2 | L1           |
| b) In an n-channel FET, the effective channel width is $3 \times 10^{-4}cm$ and the donor impurity concentration is $10^{15}$ electrons/cm <sup>3</sup> . <b>Find</b> the pinch-off voltage?   | 8M    | CO2 | L3           |
| 4. a) With neat diagrams, explain single stage amplifier with waveforms.   | 7M    | CO3 | L2           |
| b) What is the importance of input impedance in amplifier circuit, Explain   | 7M    | CO3 | L2           |
| 5. a) Explain ac and dc load lines. What is the significance of Q-point?   | 7M    | CO3 | L1, L2       |
| b) Define voltage gain, ac emitter resistance? Derive the voltage gain in terms of ac emitter resistance?  | 7M    | CO3 | L1, L3       |
| 6. a) <b>Draw</b> the small-signal model of common drain FET amplifier. Derive expressions for voltage gain and output resistance?   | 7M    | CO4 | L4, L6       |
| b) For the circuit shown in fig. <b>Determine</b> i) Input impedance ii) output impedance and iii) voltage gain?   |       |     |              |

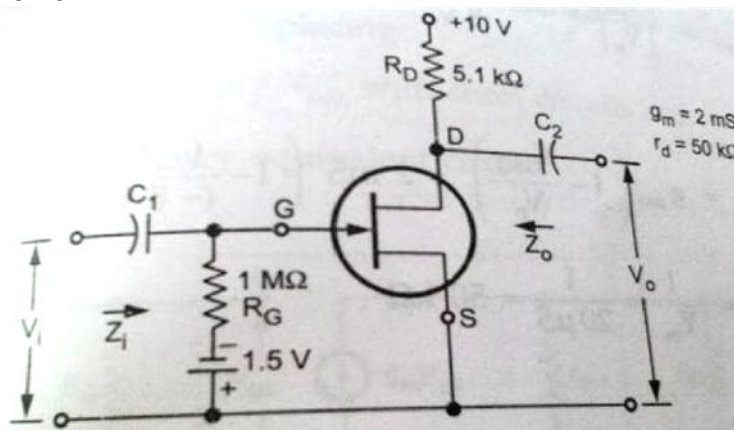

- |  |     |                  |        |
|--|-----|------------------|--------|
| 7. a) Write short notes on   |     |                  |        |
| (i) PIN diode  |     | (ii) Photo diode |        |
| b) Draw the symbol of UJT. Explain the construction of UJT and explain its operation with characteristics  | 6M  | CO5              | L2     |
| 8. Draw the symbol of Tunnel diode. Explain the construction and tunneling phenomenon of Tunnel diode. Give its applications and explain in brief. | 8M  | CO5              | L1, L2 |
|  | 14M | CO5              | L1, L2 |

\*\*\*\*\*

Hall Ticket Number : 

--	--	--	--	--	--	--	--	--	--

**R-19**

**Code: 19AC24T**

I B.Tech. II Semester Regular Examinations Nov/Dec 2020

### **Engineering Chemistry**

( Common to EEE & ECE )

Max. Marks: 70

Time: 3 Hours

Answer any five questions from the following ( 5 x 14 = 70 Marks )

\*\*\*\*\*

	Marks	CO	Blooms Level
1. a) (i) Bring out the differences between electrolytic cell and galvanic cell (ii) Write a note on calomel electrode	7M	CO1	L2
b) Discuss the classification of ion selective electrodes (ISEs) with suitable examples	7M	CO1	L3
2. a) Explain the characteristics of battery	7M	CO2	L2
b) Explain the construction and working of H <sub>2</sub> -O <sub>2</sub> fuel cell. Why is water formed in above cell removed continuously?	7M	CO2	L3
3. a) Explain the construction and working of Laclanche cell. What are the advantages and uses of this cell?	7M	CO2	L2
b) What are primary, secondary and reverse batteries? Provide examples for these batteries. Give the advantages of batteries over fuel cells	7M	CO2	L2
4. a) What is photo-voltaic (PV) cell? Explain the construction and working of PV cell.	7M	CO3	L2
b) What are intrinsic semiconductors? Explain the conduction in n-type and p-type semiconductors.	7M	CO3	L2
5. a) Discuss the production of solar grade silicon from quartz	7M	CO3	L2
b) Explain the applications of solar energy	7M	CO3	L2
6. a) Discuss the differences between thermoplastics and thermosetting plastics with suitable examples	7M	CO4	L4
b) What is plastic? Write preparation, properties and uses of the following polymers: (i) Bakelite and (ii) Nylon-6,6	7M	CO4	L4
7. a) What is meant by conducting polymers? Explain synthesis and applications of any one conducting polymer.	7M	CO4	L2
b) Describe the free radical mechanism of chain polymerization taking ethane as an example	7M	CO4	L4
8. a) What are nanowires? Give the synthesis, properties and applications of nano material.	7M	CO5	L2
b) Explain the sol-gel method for preparation of nanomaterial with an example	7M	CO5	L3

\*\*\*\*\*

**Code: 19AC25T**

I B.Tech. II Semester Regular Examinations Nov/Dec 2020

**Functional English and Life Skills**

( Common to EEE &amp; ECE )

Max. Marks: 70

Time: 3 Hours

Answer any five questions from the following ( 5 x 14 = 70 Marks )

\*\*\*\*\*

	Marks	CO	Blooms Level
1. a) 'In your father's house, you might do as you pleased: in the world, you will find competitors at every turn'- analyze these words with reference to Hazlitt's 'On the Conduct of Life'	7M	CO3	L4
b) <b>Change the following statements into questions:</b>			
i. Raju has been working in this office for five years			
ii. I will win the match whoever is my opponent.			
iii. The teacher is observing all the students with great care.	3M	CO3	L3
c) <b>Fill in the blanks with appropriate form of the underlined words:</b>			
i. <u>Hope</u> is the driving force of one's life; so let's always be _____ .			
ii. Swathi is my close <u>friend</u> . She is _____ with all the people in her life.			
iii. <u>Mighty</u> people think that _____ is right.			
iv. Rathan was <u>compelled</u> by his parents to join B.Tech. This kind of _____ will lead to the depression of the students.	4M	CO3	L3
2. a) 'When will be a human become a man? Explain your opinion quoting a few lines from Rudyard Kipling's 'If'.	7M	CO2	L2
b) <b>Rearrange the following jumbled sentences in a correct sequence:</b>			
P. So the problems of India should not be viewed in isolation.			
Q. India's uniqueness lies in its unity in diversity due to which there are problems here and there at times.			
R. India is a multi-religious, multicultural and multilingual country and is poised for success in all fields.			
S. But even small countries with monolithic society have more problems	4M	CO4	L4
c) <b>Use the following words in your own sentences:</b>			
i. Hardly            ii. Convene        iii. Pandemic	3M	CO3	L3
3. a) "GB Shaw's ' How I became a public speaker' provides a fitting example for self-improvement"- Explain	7M	CO2	L3
b) <b>Fill in the blanks with appropriate connectors/linkers:</b>			
i. A monk should have no particular attachment to his country. _____, he should view all countries his own.			
ii. Grammar rules sometimes confuse the learners of English language. _____, the learners get hesitated to learn grammar rules.	2M	CO3	L3
c) Write a paragraph in about 70 words on ' Covid-19'	5M	CO4	L4
4. a) How relevant are the views of Seneca, an ancient Roman philosopher and writer, on time to the present day people?	7M	CO1	L5
b) <b>Fill in the blanks with the suitable form of the verb given in brackets:</b>			
i. In my childhood my goal was to become an IAS officer. Now I am working as a clerk in a private company. If I had worked hard I _____ (become) an IAS officer.			
ii. Vineel _____ ( meet) her old friend when he was going to market.			
iii. Long ago there was an old king. He _____ (have) five wives and twenty five children.			
iv. Look at the river. It _____ ( flow) very fast today_ much faster than usual.	4M	CO3	L3
c) <b>Choose the correct option from the brackets:</b>			
i. One of the passengers _____ ( was/were) badly injured in the accident.			
ii. All the books which _____ (has/have) been placed on the table need rebinding.			
iii. Sekar as well as his friend _____ (is/ are) preparing for the examinations.	3M	CO3	L3
5. a) How does Chindu Yellamma's life story inspire today's young girls?	7M		

- b) Transfer the information into text

Time spent on daily activities by the employees in India



7M CO2 L2

6. a) Analyse the role of innovative ideas in the life and career of entrepreneurs citing some innovative concepts of Nobel peace prize winner Muhammad Yunus.

7M CO1 L4

- b) **Mark the following comparisons correct/wrong**

- Rajesh got more marks than his classmates.
- The climate of Bengaluru is better than that of Visakhapatnam.
- The Ganges is the most largest river in India.

3M CO3 L2

- c) **Give antonyms to the underlined words:**

Literature is the foundation of life. It places an emphasis on many topics from human tragedies to tales of the ever-popular search for love. While it is physically written in words, these words come alive in the imagination of the mind, and its ability to comprehend the complexity of the text. Literature enables people to see through the lenses of others, and sometimes even inanimate objects; therefore, it becomes a looking glass into the world as others view it.

4M CO3 L3

7. a) How does Prince Dimitri, the protagonist of Saki's one act play 'The Death trap', die? What does he do before he dies?

7M CO1 L1

- b) Summarise the following text

Value education, no doubt, is important; yet, it has become neglected subject area in today's classrooms and curriculum. However, value- education can be adequately addressed in both the classroom and college curriculum. A very convenient and successful way of communicating values to a person is through his or her education, whether in school, college or university level. Of course, learning is that process which continues right through a person's lifetime and values can be imbibed by a person through every experience and learning opportunity he or she gets. However, the ideal time to begin learning and imbibing values is right at the start of one's education that may be in pre-school or in school. A good set of values will enable a person to raise his or her self-esteem, make others hold him or her in high respect and give him or her the confidence he or she requires to lead a life based on principles and self-confidence. Most children start their education by attending a pre-school institution, i.e., a play-school or a nursery. Children in such institutions, learn tolerance and cooperation. By mixing with children of their own age who might be from different strata of society, they learn how to be tolerant of one another, cooperate with one another and to be impartial in their dealings with one another.

Developing tolerance in a person from a young age will teach the person how to get along and live peacefully. In schools, the students can be taught discipline, punctuality, honesty, perseverance and patriotism. A student can understand the value and importance of discipline only when a certain code of conduct is enforced which a student has to adhere to.

5M CO2 L4

- c) Change the following sentences into Indirect Speech:

- Smitha said to me, 'can you give me your pen?'
- Ranjan said, 'I will attend the function'

2M CO3 L3

8. Write an essay in about 200 words on 'The impact of recent lockdown on the poor in India' using the following claims

According to the World Bank's 2015 estimates, India has 176 million people living in extreme poverty- Millions in backward regions face penury and deprivation as economic activity grinds to a halt- Thousands fled on foot to their villages, often hundreds of kilometres away- Central government and state government immediate measures- future action plan .

14M CO4 L5

\*\*\*\*\*

Hall Ticket Number :

--	--	--	--	--	--	--	--	--	--	--

**R-19**

**Code: 19A521T / 19A522T**

I B.Tech. II Semester Regular Examinations Nov/Dec 2020

**Python Programming / Programming Through Python**

( Common to CE, ME & CSE ) ( Common to EEE & ECE )

Max. Marks: 70

Time: 3 Hours

Answer any five questions from the following ( 5 x 14 = 70 Marks )

\*\*\*\*\*

	Marks	CO	Blooms Level
1. Describe the various expressions in python with suitable examples.	14M	CO1	L1
2. a) Define a program that displays different data types using variables and literal constants.	7M	CO1	L1
b) Show that for a program to perform addition, subtraction, multiplication, integer division, floor division and modulo division (on two integers and float) python data types are crucial.	7M	CO1	L1
3. a) Illustrate the need and importance of function in python.	7M	CO2	L3
b) What is python List? Describe the List usage with suitable examples	7M	CO2	L1
4. a) Model a program to exchange the value of two variables with temporary variables	7M	CO2	L3
b) Examine the properties of Dictionary keys with examples	7M	CO2	L3
5. a) Write a python program to count the number of vowels in a string provided by the user.	7M	CO3	L3
b) Determine the need of Exception with Arguments.	7M	CO3	L3
6. a) Define classes in python with suitable example	7M	CO4	L1
b) Recall the fundamental object oriented concepts used in python.	7M	CO4	L1
7. Describe the concept of queue implementation using python list.	14M	CO5	L1
8. Examine abstract data type with its types along with the syntax used.	14M	CO5	L1 & L3

\*\*\*\*\*