

Hall Ticket Number :										
----------------------	--	--	--	--	--	--	--	--	--	--

R-23

Code: 23AHS21T

B.Tech. II Semester Regular Examinations July 2024
Differential Equations and Vector Calculus
 (Common to All Branches)

Max. Marks: 70

Time: 3 Hours

- Note: 1. Question Paper consists of two parts (**Part-A** and **Part-B**)
 2. In Part-A, each question carries **Two marks**.
 3. Answer **ALL** the questions in **Part-A** and **Part-B**

PART-A

(Compulsory question)

- | | | |
|---|-----|----|
| 1. Answer all the following short answer questions (10 X 2 = 20M) | CO | BL |
| a) Solve $(2x + y + 1)dx + (x + 2y + 1)dy = 0$. | CO1 | L3 |
| b) State Newton's Law of Cooling. | CO1 | L1 |
| c) Solve $(D^2 + 4D + 4)y = 0$. | CO2 | L3 |
| d) Find PI of $(D^2 + 5D + 6)y = e^{3x}$. | CO2 | L3 |
| e) Find the partial differential equation by eliminating arbitrary constants a, b from $z = ax + by + a^2 + b^2$. | CO3 | L3 |
| f) Solve $\sqrt{x} + q\sqrt{y} = \sqrt{z}$. | CO3 | L3 |
| g) Find grad f , where $f = x^2yz + xy^2z + xyz^2$. | CO4 | L1 |
| h) Show that $f = 3y^2z^2i + 3x^2z^2j + 3x^2y^2k$ is solenoidal, where $f = 3y^2z^2i + 3x^2z^2j + 3x^2y^2k$. | CO4 | L1 |
| i) Evaluate the line integral $\int_C (x^2 + xy)dx + (x^2 + y^2)dy$, where C is the square formed by the lines $x = \pm 1$ and $y = \pm 1$. | CO5 | L3 |
| j) State Green's theorem | CO5 | L1 |

PART-B

Answer **five** questions by choosing one question from each unit (5 x 10 = 50 Marks)

Marks CO BL

UNIT-I

- | | | | |
|---|----|-----|----|
| 2. a) Solve $\frac{dy}{dx} + y \tan x = y^3 \sec x$. | 5M | CO1 | L3 |
| b) Solve $(4xy + 3y^2 - x^2)dx + x(x + 2y)dy = 0$. | 5M | CO1 | L3 |

OR

- | | | | |
|---|----|-----|----|
| 3. a) Solve $(4xy + 3y^2) \frac{dy}{dx} = 1$. | 5M | CO1 | L3 |
| b) If the temperature of the air is $30^\circ C$ and the substance cools from $100^\circ C$ to $70^\circ C$ in 15 minutes. Find when the temperature will be $40^\circ C$. | 5M | CO1 | L3 |

UNIT-II

4. Solve $(D - 2)^2 y = \{e^{2x} + \sin 2x + x\}$ 10M CO2 L3

OR
OR

5. Solve the simultaneous equations $\frac{dx}{dt} + 2y + \sin t = 0$,
 $\frac{dy}{dt} - 2x - \cos t = 0$, given that $x = 0$ and $y = 1$ when $t = 0$. 10M CO2 L3

UNIT-III

6. a) Form the partial differential equation by eliminating arbitrary constants a, b and c from $(x - a)^2 + (y - b)^2 + z^2 = c^2$ 5M CO3 L3

- b) Form the partial differential equation by eliminating arbitrary functions f and g from $z = f(y + 2x) + g(y - 3x)$. 5M CO3 L3

OR
OR

7. Solve $(x^2 - yz)p + (y^2 - zx)q = z^2 - xy$. 10M CO3 L3

UNIT-IV

8. a) If $\vec{F} = \nabla(x^3 + y^3 + z^3 - 3xyz)$ find $\text{curl}(\vec{F})$. 5M CO4 L3

- b) Find the directional derivative of $\phi = x^2yz + 4xz^2$ at $(1, -2, -1)$ in the direction of the vector $2i - j - 2k$. 5M CO4 L3

OR

9. a) Find the angle between the surfaces $x^2 + y^2 - z^2 = 6$ and $x^2 + y^2 - z^2 = 13$ at $(2, 1, 2)$. 5M CO4 L3

- b) Find the value of a, b, c if $\vec{F} = (x + y + az)\hat{i} + (bx + 2y - z)\hat{j} + (x + cy + 2z)\hat{k}$ is irrotational 5M CO4 L3

UNIT-V

10. Find the work done by a force $\vec{F} = 3x^2\hat{i} + (xz - y)\hat{j} + z\hat{k}$ along the straight line from $(0, 0, 0)$ to $(2, 1, 3)$. 10M CO5 L3

OR

11. Verify Green's theorem for $\int_C (xy + y^2)dx + x^2 dy$, where C is bounded by $y = x$ and $y = x^2$. 10M CO5 L3

*** End ***

Hall Ticket Number :										
----------------------	--	--	--	--	--	--	--	--	--	--

R-23

Code: 23A0323T

B.Tech. II Semester Regular Examinations July 2024

Engineering Mechanics

(Common to CE & ME)

Max. Marks: 70

Time: 3 Hours

- Note: 1. Question Paper consists of two parts (**Part-A** and **Part-B**)
 2. In Part-A, each question carries **Two marks**.
 3. Answer **ALL** the questions in **Part-A** and **Part-B**

PART-A

(**Compulsory question**)

- | | | |
|---|----|----|
| 1. Answer all the following short answer questions (10 X 2 = 20M) | CO | BL |
| a) What are the characteristics of a force? | 1 | L1 |
| b) What do you mean by free body diagram and redundant support? | 1 | L1 |
| c) Define angle of friction and cone of friction. | 2 | L1 |
| d) What are the assumptions in the analysis of plane trusses? | 2 | L2 |
| e) Differentiate centroid and center of gravity. | 3 | L2 |
| f) State perpendicular axis theorem applicable to area moment of inertia. | 3 | L1 |
| g) What is the difference between rectilinear and curvilinear translations? | 4 | L2 |
| h) Define range and maximum height of a projectile. | 4 | L1 |
| i) Define impulse and momentum. | 5 | L1 |
| j) What is virtual work? State virtual work principle. | 5 | L1 |

PART-B

Answer **five** questions by choosing one question from each unit (5 x 10 = 50 Marks)

Marks CO BL

UNIT-I

2. Two identical rollers, each of weight $Q = 100\text{ N}$, are supported by an inclined plane and a vertical wall as shown in Figure 1. Assuming smooth surfaces, find the reactions induced at the points of support A, B and C.

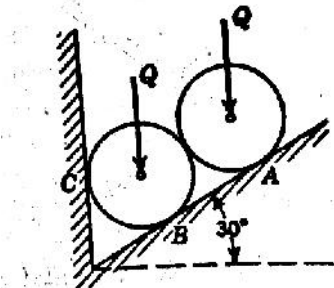

Figure 1
OR

10M 1 L3

3. Two forces of magnitude 250 N and 190 N are acting at a point O as shown in figure. If the angle between the forces is 60° , determine the magnitude of the resultant force. Also determine the angle α and β as shown in figure.1.

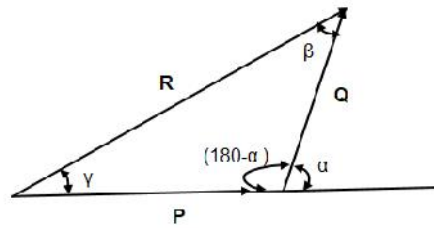

Fig.1

10 1 L3

UNIT-II

4. Find the forces in all the 8 members of the truss shown in Figure 3.

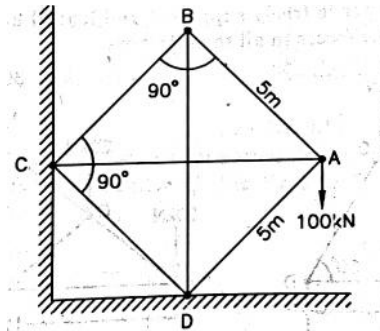

Figure 3

10M 2 L3

OR

5. Two blocks of weights W_1 and W_2 rest on a rough inclined plane and are connected by a short piece of string as shown in Figure 4. If the coefficients of friction are $\mu_1 = 0.2$ and $\mu_2 = 0.3$, respectively, find the angle of inclination of the plane for which sliding will impend. Assume $W_1 = W_2 = 20$ N.

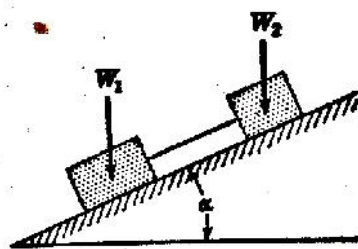
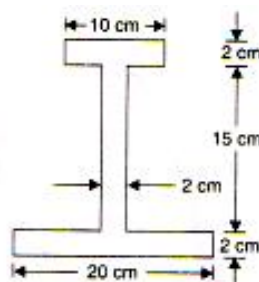

Figure 4

10M 2 L3

UNIT-III

6. Find the center of gravity of I-Section show in.



10M 3 L3

OR

7. Derive an expression for the moment of inertia of a right circular cone of uniform density, radius of base a , and altitude h , with respect to its geometric axis. 10M 3 L2

UNIT-IV

8. a) Explain about kinematics of rectilinear translation. 4M 4 L2
 b) A ship while being launched slips down the skids with uniform acceleration. If 10 sec is required to traverse the first 4.9 m, what time will be required to slide the total distance of 122 m? With what velocity will the ship strike the water? 6M 4 L3

OR

9. a) Explain about kinematics of plane motion. 4M 4 L2
 b) The armature of an electric motor has angular speed $N=1800\text{rpm}$ at the instant when the power is cut off. If it comes to rest in 6 seconds,
 (i) Calculate the angular deceleration assuming that it is constant.
 (ii) How many complete revolutions does the armature make during this period? 6M 4 L3

UNIT-V

10. Neglecting friction and inertia of the two pulleys shown in Figure 6 find the acceleration a of the weight Q , assuming that $P = Q$.

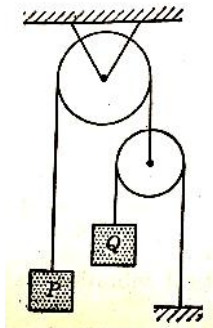

Figure 6

10M 5 L3

OR

11. A body of weight 8 N is suspended by a light rope wound round a pulley of weight 60 N and radius 30 cm. The other end of rope is fixed to the periphery of the pulley. If the weight is moving downwards, calculate for the acceleration of 8 N weight and tension in the string. 10M 5 L3

*** End ***

Hall Ticket Number :

R-23

Code: 23A0322T-C

B.Tech. II Semester Regular Examinations July 2024

Engineering Graphics

(Common to CE, ME and AI&ML)

Max. Marks: 70

Time: 3 Hours

Answer five questions by choosing one question from each unit (5 x 14 = 70 Marks)

	Marks	CO	BL
UNIT-I			
1. Draw an involute of a hexagon of side 25 mm. Draw the tangent and normal at any point on the involute.	14M	1	3
OR			
2. A line of 1 centimeter represents an actual length of 4 dm. Draw a plain scale and mark a distance of 6.7 m on it.	14M	1	3
UNIT-II			
3. Draw the projections of the following points on a common reference line keeping the distance between their projectors 30mm apart. (a) Point P is 35 mm below the H.P. and in the V.P. (b) Point Q is 40 mm in front of the V.P. and 25 mm below the H.P. (c) Point R is 45 mm above the H.P. and 20 mm behind the V.P. (d) Point S is 30 mm below the H.P. and 45 mm behind the V.P. (e) Point T is both in H.P. and V.P. (f) Point U is 40 mm above the H.P. and on V.P. (g) Point V is 20 mm behind the V.P. and on H.P.	14M	2	3
OR			
4. A 70 mm long line PQ, has its end P 20 mm above the H.P. and 30 mm in front of the V.P. The line is inclined at 45° to the H.P. and 30° to the V.P. Draw its projections.	14M	2	3
UNIT-III			
5. A hexagonal plane of side 30 mm has an edge on the H.P. Its surface is inclined at 45° to the H.P. and the edge on which the plane rests is inclined at 30° to the V.P. Draw its projections.	14M	3	3
OR			
6. A cylinder of base diameter 50 mm and axis 70 mm has a generator in the V.P. and inclined at 45° to the H.P. Draw its projections.	14M	3	3
UNIT-IV			
7. A pentagonal pyramid of base side 30 mm and axis 60 mm is resting on its base in the H.P. with an edge of the base parallel to the V.P. A horizontal section plane cuts the pyramid bisecting the axis. Draw its front view and sectional top view.	14M	4	3
OR			

8. A cone of base diameter 50 mm and axis 60 mm is resting on its base on the H.P. A section plane perpendicular to V.P. and inclined at 45° to H.P., bisects the axis of the cone. Draw the development of its lateral surface.

14M 4 3

UNIT-V

9. The front and side views of an object are shown in Fig. Draw its isometric view.

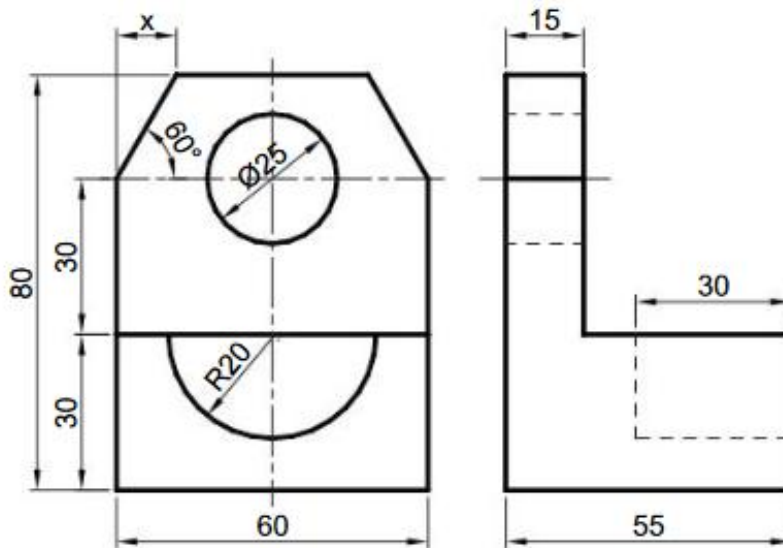

14M 5 3

OR

10. Draw the front view, top view and side view to the following isometric view

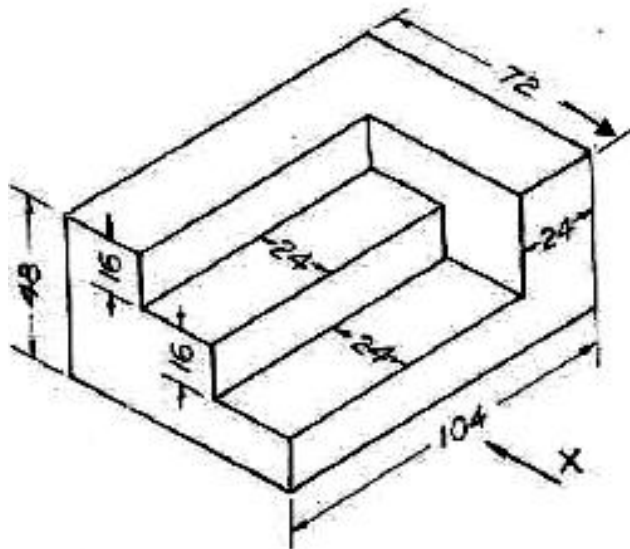

14M CO5 L3

*** End ***

Hall Ticket Number :										
----------------------	--	--	--	--	--	--	--	--	--	--

R-23

Code: 23AHS25T

B.Tech. II Semester Regular Examinations July 2024

Engineering Physics

(Common to CE, ME, CSE, CSE(DS) and AI&ML)

Max. Marks: 70

Time: 3 Hours

Note: 1. Question Paper consists of two parts (**Part-A** and **Part-B**)

2. In Part-A, each question carries **Two marks**.

3. Answer **ALL** the questions in **Part-A** and **Part-B**

PART-A

(Compulsory question)

- | | | | |
|---|------------------|-----|----|
| 1. Answer all the following short answer questions | (10 X 2 = 20M) | CO | BL |
| a) Define interference and diffraction. | | CO1 | L1 |
| b) What is resolving power of grating? | | CO1 | L2 |
| c) Define the terms lattice and basis. | | CO2 | L1 |
| d) What are miller indices? | | CO2 | L2 |
| e) Write the relation between relative permittivity and susceptibility. | | CO3 | L4 |
| f) Define the terms Magnetic permeability and susceptibility. | | CO3 | L1 |
| g) What are matter waves? | | CO4 | L1 |
| h) State Heisenberg uncertainty principle. | | CO4 | L1 |
| i) What is Hall effect? | | CO5 | L2 |
| j) What is n type semiconductor. | | CO5 | L2 |

PART-B

Answer **five** questions by choosing one question from each unit (5 x 10 = 50 Marks)

Marks CO BL

UNIT-I

- | | | | |
|--|----|-----|----|
| 2. a) Explain interference in thin film due to reflected light and derive the bright and dark fringe conditions. | 6M | CO1 | L2 |
| b) Describe colors in thin film and write examples. | 4M | CO1 | L2 |

OR

- | | | | |
|---|----|-----|----|
| 3. a) Explain construction and working of Nicol's prism to produce polarized light. | 6M | CO1 | L4 |
| b) Describe polarization of light by reflection. | 4M | CO1 | L2 |

UNIT-II

- | | | | |
|--|----|-----|----|
| 4. a) Calculate coordination number and packing fractions for SC, BCC and FCC. | 6M | CO2 | L2 |
| b) Derive the equation for interplanar spacing. | 4M | CO2 | L2 |

OR

5. a) Explain the crystal structure determination by powder method. 6M CO2 L4
 b) Derive Bragg's law of X-ray diffraction. 4M CO2 L2

UNIT-III

6. Define types of polarizations in dielectrics and derive the expression for electronic polarizability. 10M CO3 L1

OR

7. a) Distinguish among dia, para and ferro magnetic materials. 6M CO3 L4
 b) Explain briefly about Hysterisis concept in ferromagnetism. 4M CO3 L2

UNIT-IV

8. a) Derive the equation for eigen values of a particle in one dimensional potential box. 6M CO4 L4
 b) Calculate the energies of first and second quantum states of a particle confined to a potential box of length $2A^0$. 4M CO4 L3

OR

9. a) Derive the expression for electrical conductivity according to quantum free electron theory. 6M CO4 L5
 b) Write the differences between classical and quantum free electron theory. 4M CO4 L4

UNIT-V

10. a) Derive the concentration of electrons in the conduction band of intrinsic semiconductors. 6M CO5 L5
 b) Write the expression for electrical conductivity in intrinsic semiconductors. 4M CO5 L5

OR

11. a) Derive drift and diffusion currents? 6M CO5 L2
 b) Deduce Einstein' equation. 4M CO5 L2

*** End ***

Hall Ticket Number :

--	--	--	--	--	--	--	--	--	--	--

R-23

Code: 23A0221T

B.Tech. II Semester Regular Examinations July 2024

Basic Electrical & Electronics Engineering

(Common to CE, ME, CSE, CSE(DS) and AI&ML)

Max. Marks: 70

Time: 3 Hours

- Note: 1. Question Paper consists of two parts (**Part-1** and **Part-2**)
2. Use separate Answer booklets for **Part-1** and **Part-2**
3. Part-1 & Part-2 of question paper consists of Part-A & Part-B
4. In Part-A, each question carries **One mark**.
5. Answer **ALL** the questions in **Part-A** and **Part-B**

PART-1

PART-A

(Compulsory question)

1. Answer **all** the following short answer questions (5 X 1 = 5M)
- | | CO | BL |
|---|----|----|
| a) State the Kirchhoff's current law? | 1 | 1 |
| b) Define the term RMS value? | 1 | 1 |
| c) What is the basic principle of three phase induction motor? | 2 | 1 |
| d) Which type of instruments is used for measuring DC voltages and DC currents? | 2 | 1 |
| e) What is the working principle of fuse? | 3 | 1 |

PART-B

Answer **any three** questions by choosing one question from each unit (3x10=30 Marks)

Marks CO BL

UNIT-I

2. State and explain the Superposition theorem with an example? 10M 1 2
- OR**
3. Explain the following terms with respect to alternating quantities with the help of neat diagram
- i) Phase and Phase difference ii) Frequency and period
- iii) Resistance and impedance 10M 1 2

UNIT-II

4. Explain the operating principle of DC generator and single phase transformer with neat diagram? 10M 2 2
- OR**
5. Describe the construction and working of Moving coil instruments? 10M 2 2

UNIT-III

6. Briefly explain the operation of nuclear power station with a neat sketch? 10M 3 2
- OR**
7. a) Explain the safety precautions to avoid electric shock? 5M 3 2
b) Discuss the calculation of electricity bill for domestic consumers? 5M 3 2

Basic Electrical & Electronics Engineering

(Common to CE, ME, CSE, CSE(DS) and AI&ML)

PART-2**PART-A****(Compulsory question)**

- | | | | |
|--|----------------|-----|----|
| 1. Answer all the following short answer questions | (5 X 1 = 5M) | CO | BL |
| a) Draw the forward characteristics of p-n junction diode. | | CO1 | 2 |
| b) Define the Zener effect in Zener diodes. | | CO1 | 1 |
| c) Describe the difference between intrinsic and extrinsic semiconductors. | | CO2 | 1 |
| d) Sketch the circuit diagram of Full wave rectifier circuits. | | CO2 | 1 |
| e) Convert $(1001)_2$ into a decimal number. | | CO2 | 3 |

PART-B**Answer any three questions by choosing one question from each unit (3x10=30 Marks)**

Marks CO BL

UNIT-I

- | | | | |
|--|-----|-----|--|
| 2. Sketch the input and output characteristics of common emitter transistor configuration and explain briefly. | 10M | CO3 | |
|--|-----|-----|--|

OR

- | | | | |
|---|-----|-----|--|
| 3. Explain the VI characteristics of PN junction diode. | 10M | CO3 | |
|---|-----|-----|--|

UNIT-II

- | | | | |
|---|-----|-----|--|
| 4. Describe the working principle of a Zener diode. How is it used for voltage regulation? Provide a circuit diagram and explain its operation under different load conditions. | 10M | CO4 | |
|---|-----|-----|--|

OR

- | | | | |
|--|-----|-----|--|
| 5. With a neat circuit diagram and waveforms explain the working of full wave bridge rectifier with C filter | 10M | CO4 | |
|--|-----|-----|--|

UNIT-III

- | | | | |
|--|----|-----|--|
| 6. a) Design a full adder with two half adders | 5M | CO5 | |
| b) Describe the working of JK flip flop with help of its truth table | 5M | CO5 | |

OR

- | | | | |
|--|----|-----|--|
| 7. a) Verify the truth tables of various logic gates | 5M | CO5 | |
| b) Write a short notes on | | | |
| i) Resistors | | | |
| ii) Counters | 5M | CO5 | |

*** End ***