

Hall Ticket Number :

--	--	--	--	--	--	--	--	--	--	--

R-15

Code: 5G121

I B.Tech. II Semester Supplementary Examinations May 2018

C Programming and Data Structures

(Common to All Branches)

Max. Marks: 70

Time: 3 Hours

Answer all five units by choosing one question from each unit (5 x 14 = 70 Marks)

UNIT-I

1. a) Define pointer and explain about pointer arithmetic. 7M
- b) List the four dynamic memory allocation functions in C and give their syntax with examples. 7M

OR

2. a) What are the features and uses of pointers? 7M
- b) Write a C program to add two numbers using command line arguments. 7M

UNIT-II

3. a) Differentiate between structure and union. 6M
- b) Give the tracing of quick sort algorithm for the data [1, 2, 3, 4, 5, 6, 7, 8] to be sorted in ascending order. Discuss its time complexity. 8M

OR

4. a) Write a program in C to copy the contents of one file to another. 7M
- b) Write an iterative algorithm for binary search and discuss its time complexity. 7M

UNIT-III

5. a) Convert the following infix expressions to postfix expressions.
i) $A + B * C + D$ ii) $(A + B) * (C + D)$ iii) $A + B + C + D$ 6M
- b) Write a program in C to implement operations on queue.(Use pointers) 8M

OR

6. a) Write an algorithm to evaluate a postfix expression. 8M
- b) Give the advantages and disadvantages of recursion. 6M

UNIT-IV

7. a) Write a C program for insertion operation in a singly linked list. 7M
- b) Write C functions for insertion and deletion operations in doubly linked list. 7M

OR

8. a) Write a recursive program to reverse the given singly linked list. 8M
- b) Give the applications of circular linked list. 6M

UNIT-V

9. a) Define binary search tree. Write a C function to insert a new node in a binary search tree. 8M
- b) Give the applications of graphs. 6M

OR

10. a) Write a C function to search a given key in a given binary search tree. 8M
- b) Define the following regarding graphs. 6M
- i) Undirected graph ii) In degree iii) Digraph

Hall Ticket Number :

--	--	--	--	--	--	--	--	--	--	--

R-15

Code: 5G522

I B.Tech. II Semester Regular Examinations May 2018

Engineering Graphics –II

(Common to CE & ME)

Max. Marks: 70

Time: 3 Hours

Answer all five units by choosing one question from each unit (5 x 14 = 70 Marks)

UNIT-I

1. Draw the projections of a cylinder, base 25 mm radius and axis 70 mm long, resting on one of its generator on the H. P., with the axis inclined at 45° to the V. P.

OR

2. A pentagonal pyramid, base 30 mm side and axis 50 mm long has one of triangular faces in V.P. and the edge of the base contained by that face makes an angle of 30 degrees with the H.P. Draw its projections.

UNIT-II

3. A rectangular prism 30 mm x 60 mm and height 100 mm is standing on the base on the ground with the longer edges of the base parallel to the VP. It is cut by an AIP plane to give the view from above the section as a square of 30 mm sides. Draw an auxiliary View with the true shape of the section and find the inclination of the auxiliary inclined plane with the ground.

OR

4. A cylinder of base 40 mm diameter and height 60 mm is standing on one of the points on the base circle and the base makes 30° to the ground and the axis is parallel to the V.P. The axis leans towards the right. The object is cut by a section plane such that the view from the right shows the true shape of the section. The top most portion of the section is 50 mm above the ground. Draw the true shape of the section and also find the inclination of the section plane with the V.P and H.P.

UNIT-III

5. A vertical cylinder of 70 mm diameter is penetrated by a horizontal cylinder of the diameter 50mm. The axis of horizontal cylinder is parallel to both H.P and V.P and is bisecting the axis of the vertical cylinder. Draw the projections showing the lines of intersection

OR

6. A pentagonal prism having a base with 30 mm side and 65 mm long axis, is resting on its base in the H.P. with a rectangular face parallel to the V.P. It is cut by a section plane perpendicular to the V.P., inclined at 30° with the H.P., and passing through a point on the axis, 25 mm from one of the bases. Draw the development of its lateral surface.

UNIT-IV

7. A hexagonal prism with a 30 mm base and 45 mm axis has an axial hole with a 30 mm diameter. Draw its isometric projection.

OR

8. A hexagonal prism of base edge 30 mm and height 70mm long is resting on its rectangular face on the ground with its axis parallel to the VP. A square prism of 20 mm base edge and height 40 mm rests on its base on the top rectangular face of the hexagonal prism. The axis of the square prism intersects and bisects the axis of the hexagonal prism when produced. One of the base edges of the square prism is parallel to the VP. Draw an isometric projection of the set up.

UNIT-V

9. Draw the front view, top view and side view of the object whose isometric view is shown in the Figure below (All dimensions are in mm).

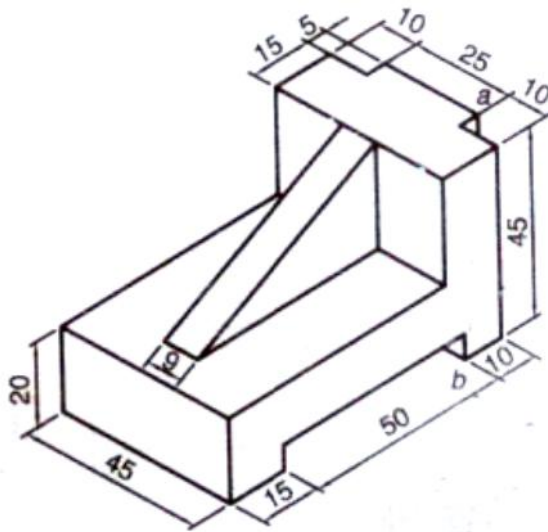

OR

10. Draw isometric view for the following orthographic projection.

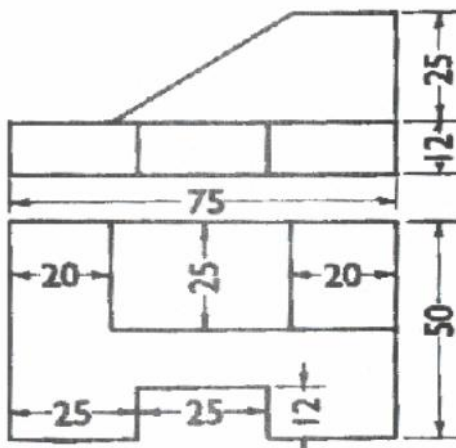

Hall Ticket Number :

--	--	--	--	--	--	--	--	--	--

R-15

Code: 5G521

I B.Tech. II Semester Supplementary Examinations May 2018

Engineering Mechanics - Dynamics

(Common to CE & ME)

Max. Marks: 70

Time: 3 Hours

Answer all five units by choosing one question from each unit (5 x 14 = 70 Marks)

UNIT-I

- a) Derive the equations of rectilinear motion of a particle moving with constant acceleration. 7M
b) A stone is dropped into a well and falls vertically with constant acceleration $g=9.81 \text{ m / s}^2$. The sound of impact of the stone is on the bottom of the well is heard 6.5 sec after it is dropped. If the velocity of sound is 336.33 m / s , how deep is the well ? 7M

OR

- a) Define normal and tangential components of accelerations. Write the equations. 4M
b) The pilot of an airplane A flying horizontally with constant speed $v = 450 \text{ kmph}$ at an elevation $h = 600 \text{ m}$ above a level plain wishes to bomb a target B on the ground (Figure.1). At what angle below the horizontal should he see the target at the instant of releasing the bomb in order to score a hit?

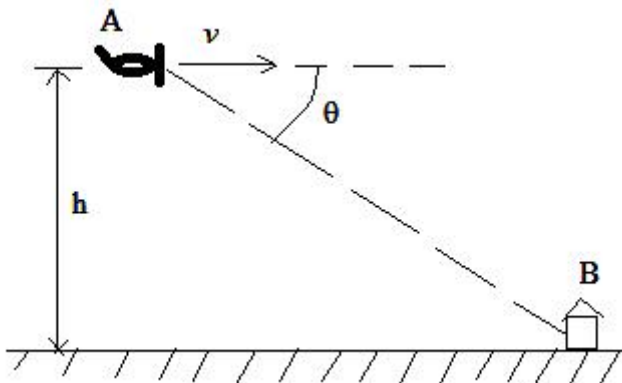

Figure.1

10M

UNIT-II

- a) Explain about kinematics of rotation of a rigid body. 7M
b) The armature of an electric motor has angular speed $N = 1800 \text{ rpm}$ at the instant when the power is cut off. If it comes to rest in 6 seconds,
(i) Calculate the angular deceleration assuming that it is constant.
(ii) How many complete revolutions does the armature make during this period? 7M

OR

- a) What is instantaneous center of rotation of a rigid body making plane motion? Explain with an example. 7M
b) A locomotive runs along a straight level track with constant acceleration $a=0.2g$. Find the total acceleration of a point at the top of the rim of a driver wheel of radius $r = 1 \text{ m}$ when the speed of the locomotive is 25 kmph . 7M

UNIT-III

5. a) Explain Virtual work principle and D'Alembert's principle with an example. 7M
- b) A police investigation of tire marks shows that a car travelling along a straight level street had skidded for a total distance of 40 m after the brakes were applied. The coefficient of friction between tires and pavement is estimated to be $\mu = 0.6$. What was the probable speed of the car when the brakes were applied? Assume constant deceleration for the car. 7M

OR

6. a) Two weights P and Q are connected by the arrangement shown in Figure.2. Neglecting friction and the inertia of the pulleys and cord, find the acceleration 'a' of the weight Q. Also find the tension in the cord. Assume that $P = 40 \text{ KN}$ and $Q = 30 \text{ KN}$.

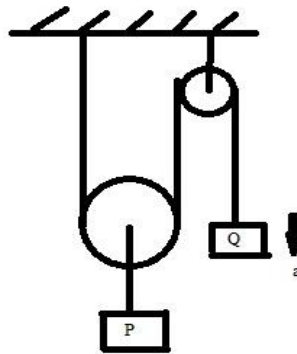

Figure.2

- b) A locomotive of weight $W = 600 \text{ KN}$ goes around a curve of radius $r = 300 \text{ m}$ at a uniform speed of 70 kmph . Determine the total lateral (outward) thrust on the rails. 7M

UNIT-IV

7. a) State and prove Work-Energy principle of rectilinear translation. 7M
- b) When a ball of weight 'W' rests on a spring of constant 'k', it produces a static deflection of 25 mm. How much will the same ball compress the spring if it is dropped from a height $h = 300 \text{ mm}$? Neglect the mass of the spring. 7M

OR

8. a) State and prove Impulse – Momentum principle 7M
- b) A locomotive weighing 60 tons has a velocity of 15 kmph and backs into a freight car weighing 10 tons that is at rest on a level train track. After the coupling is made, with what velocity 'v' will the entire system continue to move? 7M

UNIT-V

9. a) Derive the equation of motion of a rigid body rotating about a fixed axis. 7M
- b) A homogeneous sphere, of radius $a = 0.25 \text{ m}$ and weight $W = 1 \text{ KN}$, can rotate freely about a diameter. If it starts from rest and gains, with constant angular acceleration, an angular speed of $n = 180 \text{ rpm}$ in 12 revolutions, find the acting moment 'M'. 7M

OR

10. A constant force of 100N is applied tangentially on a cylinder at rest, whose mass is 50kg and radius is 10cm, for a distance of 5m. Determine the angular velocity of its centre of mass. Assume that there is no slip. 14M

Code: 5GC24

I B.Tech. II Semester Supplementary Examinations May 2018

Engineering Mathematics-II

(Common to All Branches)

Max. Marks: 70

Time: 3 Hours

Answer all five units by choosing one question from each unit (5 x 14 = 70 Marks)

UNIT-I

1. Change the order of integration in $\int_0^1 \int_x^{\sqrt{2-x^2}} \frac{x}{\sqrt{x^2+y^2}} dy dx$ and hence evaluate it. 14M

OR

2. Evaluate $\int_1^e \int_1^{\log y} \int_1^{e^x} \log z dz dx dy$. 14M

UNIT-II

3. a) Find the Laplace transform of $te^{-t} \sin 3t$. 7M

- b) Find the Laplace transform $\int_0^\infty t \sin t dt$. 7M

OR

4. a) Find $L^{-1} \left\{ \frac{1}{(s^2+1)^2} \right\}$ by convolution theorem. 7M

- b) Find $L^{-1} \left\{ \frac{s}{(s^2+a^2)^2} \right\}$ by convolution theorem. 7M

UNIT-III

5. Solve $(D^2+9)x = \sin t$ using Laplace transform given that $x(0)=1$, $x(\frac{\pi}{2})=1$. 14M

OR

6. Solve $y'' - 3y' + 2y = 4t + e^{3t}$, $y(0)=1$, $y'(0)=1$. 14M

UNIT-IV

7. a) Find the directional derivative of $f(x,y,z) = xy^3 + yz^3$ at the point $(2, -1, 1)$ in the direction of vector $\bar{i} + 2\bar{j} + 2\bar{k}$. 7M

- b) Show that $\text{div}(\text{grad } r^n) = n(n+1) r^{n-2}$. 7M

OR

8. A vector field is given by $\bar{f} = \sin y \bar{i} + \cos y \bar{j}$. Evaluate the line integral over a circular path given by $x^2 + y^2 = a^2$, $z=0$. 14M

UNIT-V

9. Verify Green's theorem for $\int_C [(xy+y^2)dx + x^2dy]$, where C is bounded by $y=x$ and $y=x^2$. 14M

OR

10. Verify Stoke's theorem for $\bar{f} = (2x-y)\bar{i} - yz^2\bar{j} - y^2z\bar{k}$ over the upper half surface of the sphere $x^2 + y^2 + z^2 = 1$ bounded by the projection of the xy plane. 14M

Hall Ticket Number :

--	--	--	--	--	--	--	--	--	--

R-15

Code: 5GC23

I B.Tech. II Semester Supplementary Examinations May 2018

Engineering Physics

(Common to CE, ME, CSE and IT)

Max. Marks: 70

Time: 3 Hours

Answer all five units by choosing one question from each unit (5 x 14 = 70 Marks)

UNIT-I

1. Write a detailed note on optical fibres.
- OR**
2. Distinguish between single slit and double slit Fraunhofer diffraction.

UNIT-II

3. Define and explain Bravais lattice
- OR**
4. Prove that FCC is more closely packed than BCC and SC.

UNIT-III

5. a) Explain the classification of solids on the basis of energy band theory
b) Describe Fermi-Dirac distribution function
- OR**
6. a) Find de-Broglie wave length of an electron accelerated in field of potential 1600V
b) Derive 1-D Schrödinger wave equation

UNIT-IV

7. a) What are donor and acceptor impurities? Give examples.
b) With the help of neat diagram explain the formation of p-n Junction. Give its I-V Characteristics.
- OR**
8. a) State and explain Hall effect.
b) Derive the expression for Hall coefficient and discuss the importance of Hall effect in semiconductors.

UNIT-V

9. a) What are Cooper pairs?
b) Explain the theory of formation of Cooper pairs
- OR**
10. a) Define nanomaterials.
b) What is the significance of nanoscale? Explain in detail.

--	--	--	--	--	--	--	--	--	--

Code: 5GC21

I B.Tech. II Semester Supplementary Examinations May 2018

Technical English
(Common to All Branches)

Max. Marks: 70

Time: 3 Hours

Answer all five units by choosing one question from each unit (5 x 14 = 70 Marks)

UNIT-I

1. a) Why does the writer say that the modern technology acts like a foreign body and it has become inhuman? 7M
- b) Complete the table with the noun form or the verb form of the word.

Verb	Noun
alleviate	
	suffocation
exhaust	
	insignificance
product	
	sophistication
violent	

7M

OR

2. a) Write your view on "Technology with A Human Face". 7M
- b) Write the correct past tense and past participle form of each verb.

S.no	Present tense	Past tense	Past participle
1	Abridge		
2	Back		
3	Campaign		
4	Leap		
5	Shine		
6	Sink		
7	alleviate		

7M

UNIT-II

3. a) How has human development affected climate patterns on the Earth? 7M
- b) Write a letter to BHEL requesting the General Manager to permit you to do practical training on the topic "Electrical Drives" for one Month in August 2018. 7M

OR

4. a) What is the inter relation between human strategies and climate change? 7M
- b) Fill up the blanks with the correct form of the verbs, given in the brackets.
- i. Human beings _____ (transform) the environment.
 - ii. We _____ (live) on the planet now
 - iii. The Sun _____ (rise) in the East.
 - iv. She _____ (visit) Taj Mahal last year.
 - v. He _____ (just complete) his home work
 - vi. Sita _____ (be) taller than Geeta.
 - vii. Venkat _____ (speak) English well

7M

UNIT-III

5. a) What is the function of Heliostats? 7M
- b) Rewrite the following sentences into interrogative sentences.
- She is a healthy woman
 - Priya watches TV every evening
 - He can climb trees easily
 - Cherry cooks his own breakfast
 - They will arrive tomorrow
 - The boy has returned the books
 - They are responsible 7M

OR

6. a) What are the various steps involved in power generation? 7M
- b) Write an e mail to your friend congratulating him on getting a job. 7M

UNIT-IV

7. a) "Water is the basic of all life", Explain. 7M
- b) Choose the correct form of the verb that agrees with the subject.
- There _____ no reason for this (is/are)
 - The average workers earnings _____ goes up dramatically (has/have)
 - Here _____ two apples (is/are)
 - My pants _____ torn (was/were)
 - Two and two _____ (make/makes) four
 - Some of the voters _____ still angry (is/are)
 - Our thanks _____ to the workers who supported the Union (go/goes) 7M

OR

8. a) Write the main causes of soil erosion? 7M
- b) Write a report on an accident you witnessed. 7M

UNIT-V

9. a) "Ignorance is the mother of evil", Explain. 7M
- b) Change the voice from the followings.
- they play cricket
 - She is taking coffee
 - Post the letter
 - Don't consult him
 - Who played foot ball yesterday
 - Had you taken coffee
 - Are you playing Chess 7M

OR

10. a) How is the word unattached explained in the Lesson The Secret of Work. 7M
- b) Write at least seven positive connotations. 7M
