

Hall Ticket Number :										
----------------------	--	--	--	--	--	--	--	--	--	--

R-15

Code: 5G521

I B.Tech. II Semester Supplementary Examinations December 2022

Engineering Mechanics–Dynamics
(Common to CE & ME)

Max. Marks: 70

Time: 3 Hours

Answer any five full questions by choosing one question from each unit (5x14 = 70 Marks)

UNIT-I

1. An electric train starts from a station and accelerates at a constant rate of 1 m/s^2 for 20s. it then runs at the maximum speed attained for the next 3 minutes and finally decelerates at a constant rate over a distance of 100 m until it comes to a stop at the next station. Find the total distance between the two stations and the time taken to travel this distance.

OR

2. Three marks A, B, and C at a distance of 100m each are made along a straight road. A car starting from rest and with acceleration passes mark-A and takes 10sec to reach B and further 8sec to reach the mark C. Calculate i). the magnitude of acceleration of car ii). The velocity of the car at A iii). Velocity of car at B iv). The distance of the mark A from starting point.

UNIT-II

3. Derive the equations of motion of a body moving along a circular path with uniform angular acceleration.

OR

4. A flywheel rotating at 300rpm reduces its speed to 240 rpm while making 10 complete revolutions. Determine its angular retardation assuming it to be uniform what is its speed after 3 seconds assuming the same retardation? Also, determine how much time is taken to come to a rest from a speed of 300 rpm.

UNIT-III

5. Determine the tensions in the strings and accelerations of blocks A and B weighing 150N and 50N connected by a string and a frictionless and weightless pulley as shown in figure.

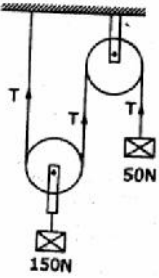

OR

6. Two blocks A and B released from rest on a 30° incline, when they are 18m apart. The coefficient of friction under the upper block-A is 0.2 and that under the lower block is 0.4. In what time block-A reaches the block-B? After they touch and move as a single unit, what will be the contact force between them? Weights of the block-A and block-B are 100N and 80N respectively.

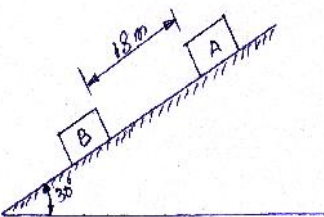

UNIT-IV

7. Determine the constant force P that will give the system of bodies shown in Fig. A velocity of 3 m/s after moving 4.5 m from rest. Coefficient of friction between the blocks and plane is 0.3. Pulleys are smooth.

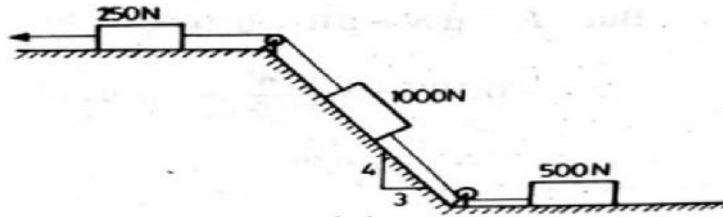

OR

8. A jet of water issued from a nozzle strikes at the center of a smooth curved vane. The water after striking the vane leaves tangential to the vane at the exit. If the jet diameter is 4mm, the velocity of the jet is 10m/s and after striking, it gets deflected through 120° , determine the force exerted by the jet of water on the vane.

UNIT-V

9. A constant force of 100N is applied tangentially on a cylinder at rest, whose mass is 50kg and radius is 10cm, for a distance of 5m. Determine the angular velocity of its centre of mass. Assume that there is no slip.

OR

10. A flywheel of 5 kg mass and 20 cm radius of gyration is directly coupled to an electric motor, which can develop 10 kw power when rotating at a speed of 1200 rpm. Determine the irving torque to maintain this speed. If power is switched off and the flywheel comes to rest in 10 seconds, determine the uniform retarding torque on the flywheel.

Code: 5GC24

I B.Tech. II Semester Supplementary Examinations December 2022

Engineering Mathematics-II

(Common to All Branches)

Max. Marks: 70

Time: 3 Hours

Answer any five full questions by choosing one question from each unit (5x14 = 70 Marks)

UNIT-I

1. Evaluate $\int_0^{\infty} \int_0^{\infty} e^{-(x^2+y^2)} dx dy$ by changing to polar coordinates. And

hence show that $\int_0^{\infty} e^{-x^2} dx = \frac{\sqrt{f}}{2}$

14M

OR

2. a) Evaluate $\int_0^{\frac{f}{2} \sin \theta} \int_0^{\frac{a^2-r^2}{a}} \int_0^a r dz dr d\theta$

7M

b) Evaluate $\int_0^{5x^2} \int_0^x x(x^2+y^2) dy dx$

7M

UNIT-II

3. a) Find the Laplace Transform of $t e^{-t} \sin t$

7M

b) Find $L^{-1} \left\{ \frac{s}{(s^2+1)(s^2+9)(s^2+25)} \right\}$

7M

OR

4. a) Find the Laplace Transform of $\int_0^t \frac{e^{-t} \sin t}{t} dt$

7M

- b) Write the Laplace Transforms of some standard functions

7M

UNIT-III

5. Solve the differential equation by Laplace Transform

$(D^2 + 2D + 5)y = e^{-t} \sin t, y(0) = 0; y'(0) = -1$

14M

OR

6. Solve the differential equation $y'' + y = t, y(0) = 1, y'(0) = 2$ Using Laplace Transform

14M

UNIT-IV

7. Using the line integral, calculate the work done by the force,

$\vec{F} = (3x^2 - 6yz)\vec{i} + (2y + 3xz)\vec{j} + (1 - 4xyz^2)\vec{k}$ in moving a particle from

the point (0,0,0) to the point (1,1,1) along the curve $C: x=t, y=t^2, z=t^3$.

14M

OR

8. a) Show the vector $(x^2 - yz)\bar{i} + (y^2 - zx)\bar{j} + (z^2 - xy)\bar{k}$ is irrotational and find its scalar potential. 7M
- b) Find the directional derivative of $2xy + z^2$ at the point $(1, -1, 3)$ in the direction of $\bar{i} + 2\bar{j} + 3\bar{k}$ 7M

UNIT-V

9. Verify the Stoke's theorem for a vector field $\bar{F} = (2x - y)\bar{i} - yz^2\bar{j} - y^2z\bar{k}$ over the upper half surface of $x^2 + y^2 + z^2 = 1$ bounded by projection on xy-plane 14M

OR

10. Verify by Green's Theorem for $\int_c [(xy + y^2)dx + x^2dy]$ where 'c' is bounded by $y=x$ and $y=x^2$ 14M

Hall Ticket Number :

R-15

Code: 5GC23

I B.Tech. II Semester Supplementary Examinations December 2022

Engineering Physics
(Common to CE, ME, CSE & IT)

Max. Marks: 70

Time: 3 Hours

Answer any five full questions by choosing one question from each unit (5x14 = 70 Marks)

Marks

UNIT-I

- 1. a) Derive the expression for Diameter of Newton's Ring 8M
- b) Explain the Diffraction grating spectrum. 6M

OR

- 2. a) Explain the production of Laser rays by ruby laser method 7M
- b) Explain optical communication system. 7M

UNIT-II

- 3. Define miller indices and write conditions for finding miller indices 6M
Derive packing fraction of S.C and B.C.C 8M

OR

- 4. a) Deduce Bragg's law equation 9M
- b) What is ultrasonic and write properties 5M

UNIT-III

- 5. a) State de-Broglie hypothesis of dual nature and derive its wavelength 10M
- b) Write the sources of electrical resistance 4M

OR

- 6. Analyze the particle in one dimensional box 14M

UNIT-IV

- 7. a) Define and explain drift and diffusion currents in semiconductors 8M
- b) what is LED brief it 6M

OR

- 8. a) Differentiate any three of dia , para , ferro, antiferro and ferrite 10M
- b) classify soft and hard magnetic materials 4M

UNIT-V

- 9. a) Explain the production of nano materials by ball milling method 10M
- b) What is CNT and explain it 4M

OR

- 10. a) Brief BCS theory and Flux quantization 8M
- b) Justify the diamagnetic nature of superconductors 6M

Hall Ticket Number :

R-15

Code: 5G121

I B.Tech. II Semester Supplementary Examinations December 2022

C Programming and Data Structures

(Common to All Branches)

Max. Marks: 70

Time: 3 Hours

Answer any five full questions by choosing one question from each unit (5x14 = 70 Marks)

UNIT-I

- 1. a) Write a program to perform addition of array elements using pointer to array. 7M
- b) Explain the declaration of pointers and pointer to pointer with examples. 7M

OR

- 2. a) Explain dynamic memory allocation functions in C in detail. 7M
- b) What is the use of command line arguments 7M

UNIT-II

- 3. a) Write a program for sorting given numbers using selection sort technique 7M
- b) Write an algorithm for Binary search? Validate it with suitable data set? 7M

OR

- 4. Write a C program that defines a structure **employee** containing the details such as **empno, empname, department name and salary**. The structure has to store 20 employees in an organization. Use the appropriate method to define the above details and define a function that will display the contents? 14M

UNIT-III

- 5. Write an algorithm to convert a given infix expression into prefix expression. 14M

OR

- 6. Write a C Program to perform the following operations on a queue
a) Insert b) Delete 14M

UNIT-IV

- 7. What is a Circular Linked List.? Explain different operations of a Circular linked list with suitable examples. 14M

OR

- 8. What are different types of linked list? Write a C function to count number of elements present in single linked list. 14M

UNIT-V

- 9. State binary search tree property. And construct the binary search tree for the following keys: G , K, L ,R, A, C, T, F, J, T, Y, E. 14M

OR

- 10. Define Graph and describe various representations of a graph with suitable examples. 14M

Hall Ticket Number :

--	--	--	--	--	--	--	--	--	--	--

R-15

Code: 5G522

I B.Tech. II Semester Supplementary Examinations December 2022

Engineering Graphics-II

(Common to CE & ME)

Max. Marks: 70

Time: 3 Hours

Answer any five full questions by choosing one question from each unit (5x14 = 70 Marks)

UNIT-I

1. Draw the projections of a cylinder, base 25 mm radius and axis 70 mm long, resting on one of its generator on the H. P., with the axis inclined at 45° to the V. P.

OR

2. A pentagonal pyramid, base 30 mm side and axis 50 mm long has one of triangular faces in V.P. and the edge of the base contained by that face makes an angle of 30 degrees with the H.P. Draw its projections.

UNIT-II

3. A cube of side 40 mm is resting on ground on one of its faces. All the vertical faces of the cube are equally inclined to VP. It is cut by a section plane perpendicular to VP and inclined to HP, so that the true shape of the section is a regular hexagon. Draw the projections, sectional top view and true shape of the section.

OR

4. A pentagonal pyramid with a 55 mm base and a 90 mm slant height, has its base on the HP with a side of base perpendicular to the VP. It is cut by a section plane whose VT is inclined at 60° to XY and intersecting the axis at 40 mm from its base. Draw the Front View, Sectional Top View, Sectional Side View, and the true shape of the section.

UNIT-III

5. A square prism of base 50 mm side and height 125 mm stands on the ground with its side of base inclined at an angle of 30° to VP. It is penetrated by a cylinder of diameter 50 mm and axis 125 mm long. The axis of the cylinder is parallel to both HP and VP and bisects the axis of the prism. Draw the projection showing fully the curves of intersection.

OR

6. A cube of 50 mm long edges is resting on the H.P. with a vertical face inclined at 30° to the V.P. It is cut by a section plane, perpendicular to the V.P. inclined at 30° to the H.P. and passing through a point on the axis, 38 mm above the H.P. Draw the sectional top view, true shape of the section and development of the surface of the remaining portion of the cube.

UNIT-IV

7. A hexagonal prism with a 30 mm base and 45 mm axis has an axial hole with a 30 mm diameter. Draw its isometric projection.

OR

8. The frustum of a sphere with a 60 mm diameter and frustum circle with a 40 mm diameter is used as a paper weight. Draw its isometric projection.

UNIT-V

9. Draw the front view, top view and right side view for the following figure

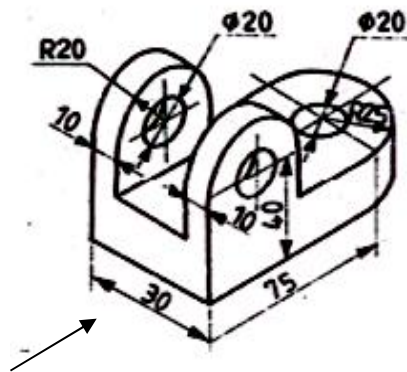

OR

10. Draw the isometric view for the following figure

