

Hall Ticket Number : 

--	--	--	--	--	--	--	--	--

**R-17**

**Code: 7G521**

I B.Tech. II Semester Supplementary Examinations November 2023

## **Engineering Graphics – II**

( Common to CE & ME)

Max. Marks: 70

Time: 3 Hours

Answer any five full questions by choosing one question from each unit (5x14 = 70 Marks )

\*\*\*\*\*

**UNIT-I**

1. A cone, base 75 mm diameter and axis 80 mm long is resting on its base on the HP. It is cut by a section plane perpendicular to the V.P inclined at  $45^{\circ}$  to the H.P and cutting the axis at a point 35 mm from the apex. Draw its front view, sectional top view, sectional side view and the true shape of the section.

**OR**

2. A pentagonal pyramid, base 30 mm side and axis 50 mm long has one of triangular faces in V.P. and the edge of the base contained by that face makes an angle of 30 degrees with the H.P. Draw its projections.

**UNIT-II**

3. A cube of side 40 mm is resting on ground on one of its faces. All the vertical faces of the cube are equally inclined to VP. It is cut by a section plane perpendicular to VP and inclined to HP, so that the true shape of the section is a regular hexagon. Draw the projections, sectional top view and true shape of the section.

**OR**

4. A pentagonal pyramid with a 55 mm base and a 90 mm slant height, has its base on the HP with a side of base perpendicular to the VP. It is cut by a section plane whose VT is inclined at  $60^{\circ}$  to XY and intersecting the axis at 40 mm from its base. Draw the Front View, Sectional Top View, Sectional Side View, and the true shape of the section.

**UNIT-III**

5. A triangular prism, having base with a 60 mm side and a 100 mm long axis, is resting on its base on the H.P. with a nearer face parallel to the V.P. It is penetrated by a cylinder with a 50 mm diameter and a 90 mm long axis. The axis of the cylinder is parallel to both the reference planes, and 15 mm away from the axis of the prism towards the observer. Draw the projections of the combination and show the curves of intersection.

**OR**

6. A pentagonal prism having a base with 30 mm side and 65 mm long axis, is resting on its base in the H.P. with a rectangular face parallel to the V.P. It is cut by a section plane perpendicular to the V.P., inclined at  $30^{\circ}$  with the H.P., and passing through a point on the axis, 25 mm from one of the bases. Draw the development of its lateral surface.

**UNIT-IV**

7. Draw the isometric view of a frustum of the cone with base diameter 60mm and top diameter 40mm with the axis height of 70mm.

**OR**

8. A hexagonal prism with a 30 mm base and 45 mm axis has an axial hole with a 30 mm diameter. Draw its isometric projection.

Important Note: 1. On completing your answers. Compulsorily draw diagonal cross line on the remaining blank pages.  
2. Any revealing of identification, appeal to evaluator and/or equations written eg. 32+8=40, will be treated as malpractice.

## UNIT-V

9. Draw isometric view for the following orthographic projection.

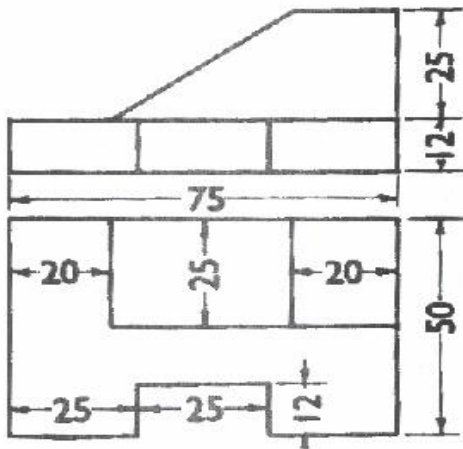

OR

10. Draw the front view, top view and side view of the solid object given below:

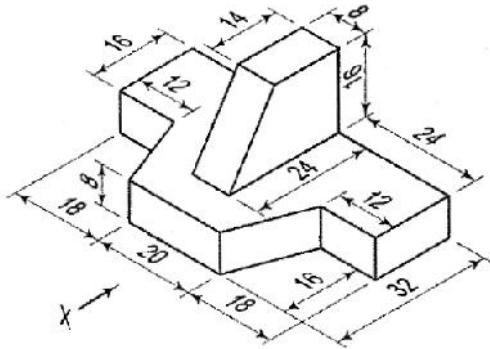

\*\*\*

Code: 7GC24

I B.Tech. II Semester Supplementary Examinations November 2023

**Engineering Mathematics – II**

(Common to All Branches)

Max. Marks: 70

Time: 3 Hours

Answer any five full questions by choosing one question from each unit (5x14 = 70 Marks )

\*\*\*\*\*

**UNIT-I**

1. a) Evaluate  $\int_0^1 \int_0^{1-z} \int_0^{1-x-y} x + y + z \, dx \, dy \, dz$  7M  
 b) Trace the curve  $r = a(1 - \cos \theta)$ . 7M

**OR**

2. a) Change the order of integration in  $\int_0^1 \int_0^{\sqrt{1-x^2}} y^2 \, dy \, dx$  and hence evaluate. 7M  
 b) Evaluate the integral by changing the order of integration  $\int_0^1 \int_{x^2}^{2-x} xy \, dx \, dy$ . 7M

**UNIT-II**

3. a) Find the Laplace Transform of  $t^2 e^{-3t}$ . 7M  
 b) Find the Laplace Transform of  $t e^{-t} \sin t$  7M

**OR**

4. a) Evaluate  $\int_0^{\infty} e^{-2t} \sin^3 t \, dt$  7M  
 b) Find the Laplace Transform of  $\int_0^t \frac{\sin t}{t} \, dt$ . 7M

**UNIT-III**

5. Find the inverse transform of  $\log\left(\frac{s+1}{s-1}\right)$ . 14M

**OR**

6. a) Find the inverse transform of  $\frac{1}{s(s^2 + a^2)}$ . 7M  
 b) Find the inverse transform of  $\frac{s+2}{s^2 - 4s + 13}$ . 7M

**UNIT-IV**

7. a) Find the angle between the surface  $x^2 + y^2 + z^2 = 9$  and  $z = x^2 + y^2 - 3$  at the point  $(2, -1, 2)$  7M  
 b) Show that  $\text{div}(\text{grad } r^n) = n(n+1)r^{n-2}$  7M

**OR**

8. a) Prove that  $\text{div curl } \vec{F} = 0$  7M  
 b) Evaluate  $\text{curl of } \vec{V} = e^{xyz}(\vec{i} + \vec{j} + \vec{k})$  at the point  $(1, 2, 3)$ . 7M

**UNIT-V**

9. Verify Gauss Divergence theorem for  $\vec{F} = x^3\vec{i} + y^3\vec{j} + z^3\vec{k}$  taken over the cube bounded by  $x=0, x=a; y=0, y=a; z=0, z=a$  14M

**OR**

10. Verify stoke's theorem for a vector field  $\vec{F} = (x^2 + y^2)\vec{i} - 2xy\vec{j}$  taken round the rectangle bounded by the lines  $x = \pm a, y = 0, y = b$ . 14M

\*\*\*

Hall Ticket Number :									
----------------------	--	--	--	--	--	--	--	--	--

**R-17**

**Code: 7G522**

I B.Tech. II Semester Supplementary Examinations November 2023

**Engineering Mechanics – Dynamics**  
(Common to CE & ME)

Max. Marks: 70

Time: 3 Hours

Answer any five full questions by choosing one question from each unit (5x14 = 70 Marks )

\*\*\*\*\*

**UNIT-I**

1. a) A particle moves along a straight line so that its displacement in metre from a fixed point is given by,  $s = t^3 + 3t^2 + 4t + 5$ . Find :  
 (i) Velocity at start and after 4 seconds    (ii) Acceleration at start and after 4 seconds.
- b) A stone dropped into a well is heard to strike the water after 4 seconds. Find the depth of the well, if the velocity of sound is 350 m/sec.

**OR**

2. A ball is thrown from the ground with a initial velocity of 20 m/s at an angle of  $30^\circ$  to the horizontal. Determine (i) the velocity of the ball at  $t=1.5$  s, (ii) total time of flight of the ball, (iii) Maximum height reached, (iv) range of the ball and (v) maximum range.

**UNIT-II**

3. A flywheel rotating at 300rpm reduces its speed to 240 rpm while making 10 complete revolutions. Determine its angular retardation assuming it to be uniform what is its speed after 3 seconds assuming the same retardation? Also, determine how much time is taken to come to a rest from a speed of 300 rpm.

**OR**

4. Two points A and B located 10 cm apart on a rotating disc have velocities respectively 10 m/s and 15 m/s. Determine (i) the angular velocity of the disc, and (ii) the radial distances of points A & B.

**UNIT-III**

5. Two bodies of mass 100 kg and 40 kg are connected by a thread and move along a horizontal plane under the action of a force 450 N applied to the first body of mass 100 kg as shown in figure. The coefficient of friction between the sliding surfaces of bodies and the plane is 0.3. Determine the acceleration of the two bodies and the tension in the thread using D'Alembert's principle.

**OR**

6. Determine the tensions in the strings and accelerations of blocks A and B weighing 150N and 50N connected by a string and a frictionless and weightless pulley as shown in figure.

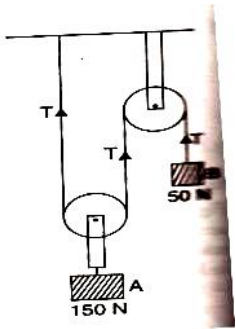

## UNIT-IV

7. A jet of water impinges on a symmetrically curved vane at its center. The velocity of the jet is 60 m/s and the diameter 120 mm. The jet is deflected through an angle of  $120^\circ$ . Calculate the force on the vane if the vane is fixed. Also determine the force if the vane moves with a velocity of 25 m/s in the direction of the jet.

OR

8. a) Derive impulse – momentum equation.  
 b) A jet of water 6 mm moves at 15 m/s issued from a nozzle strikes normally a smooth fixed plate. The water after striking the plate leaves parallel to the plate. Determine the force exerted by the jet of water on the plate.

## UNIT-V

9. A string is wound several times around a solid cylinder of 2 kg mass. The free end of the string is fixed to the ceiling and the cylinder is released from rest. Determine its velocity after it has fallen through a height of 2 m. also, determine the tension in string,

OR

10. A solid cylinder and a thin hoop of equal mass and radius are connected by a bar C1 C2 as shown in Fig.. If the assembly rolls down the incline without slip, determine the acceleration of the assembly and the tension in the bar.

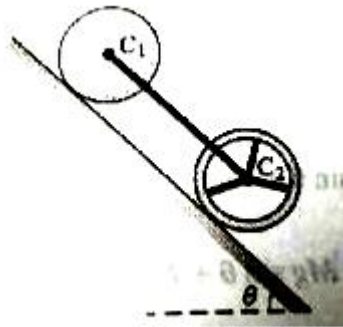

\*\*\*

Hall Ticket Number :										
----------------------	--	--	--	--	--	--	--	--	--	--

<b>R-17</b>
-------------

**Code: 7GC23**

I B.Tech. II Semester Supplementary Examinations November 2023

**Engineering Physics**

(Common to CE, ME & CSE)

Max. Marks: 70

Time: 3 Hours

Answer any five full questions by choosing one question from each unit (5x14 = 70 Marks)

\*\*\*\*\*

	Marks
<b>UNIT-I</b>	
1. a) Analyze Einstein's co-efficient for spontaneous and Stimulated emission of radiation	8M
b) Summarize Ruby, He-Ne and Semiconductor Lasers	6M
<b>OR</b>	
2. a) Recite the ruby laser for production of laser	8M
b) Describe construction of optical fiber	6M
<b>UNIT-II</b>	
3. a) Write steps to find Miller indices	6M
b) Define ultrasonics and write its properties	8M
<b>OR</b>	
4. a) Illustrate the powder method to describe the structure of crystal	6M
b) Explain production and detection of ultrasonics in detail	8M
<b>UNIT-III</b>	
5. Analyze motion of electron in periodic potential of metal	14M
<b>OR</b>	
6. a) Brief the physical importance of Schrodinger's equation	7M
b) Explain postulates of free electron model	7M
<b>UNIT-IV</b>	
7. a) What is photo diode explain it	6M
b) Explain direct and indirect band gap semiconductors	8M
<b>OR</b>	
8. a) Derive Hall voltage and justify its importance	6M
b) Define and explain drift and diffusion currents in semiconductors	8M
<b>UNIT-V</b>	
9. a) Classify the ferromagnetics by hysteresis property	6M
b) What is CNT and explain it	8M
<b>OR</b>	
10. a) Define magnetic materials write any two examples	5M
b) Brief the basic principles of nano materials	9M

\*\*\*

Hall Ticket Number :										
----------------------	--	--	--	--	--	--	--	--	--	--

**R-17**

**Code: 7G121**

I B.Tech. II Semester Supplementary Examinations November 2023

**Data Structures**

(Common to All Branches)

Max. Marks: 70

Time: 3 Hours

Answer any five full questions by choosing one question from each unit (5x14 = 70 Marks )

\*\*\*\*\*

**UNIT-I**

- 1. a) Write a program to read and display array elements using pointers 7M
- b) What is a pointer? What are the features of pointers? Write a C program to print address of a variable 7M

**OR**

- 2. a) Write a C program to swap two numbers using pointers. 6M
- b) Write a program to perform addition of array elements using pointer to array. 8M

**UNIT-II**

- 3. a) Explain different modes to open a file 7M
- b) How to copy and compare structure variables? Illustrate with example. 7M

**OR**

- 4. a) Define union. List out the differences between unions and structures 7M
- b) Write a C program to copy the contents from one file to another file. 7M

**UNIT-III**

- 5. Write a C Program to perform the following operations on a queue 14M
  - a) Insert
  - b) Delete
  - c) Display

**OR**

- 6. Show the stack after each operation of the following sequence that starts with the empty stack: push(a), push(b), pop, push(c), push(d), pop. 14M

**UNIT-IV**

- 7. What is a Doubly Linked List.? Explain different operations of a Doubly linked list with suitable examples. 14M

**OR**

- 8. Write a C program to implement the following operations on a singly Linked List 14M
  - a) Insert at beginning
  - b) deletion at end
  - c) Traversing a List

**UNIT-V**

- 9. a) Define and describe the terms: 9M
  - Tree, Binary Tree, Complete Binary Tree and Degree of a tree.
- b) Draw a complete undirected graph having five nodes. 5M

**OR**

- 10. Define Graph and describe various representations of a graph with suitable examples. 14M

\*\*\*