

Hall Ticket Number :										
----------------------	--	--	--	--	--	--	--	--	--	--

R-17

Code: 7G121

I B.Tech. II Semester Supplementary Examinations August 2021

Data Structures

(Common to All Branches)

Max. Marks: 70

Time: 3 Hours

Answer all five units by choosing one question from each unit (5 x 14 = 70 Marks)

UNIT-I

1. a) What is the use of command line arguments
b) Write a program using pointers to compute the sum of all elements stored in an array.

OR

2. a) How pointers permit inter function communication.
b) How do you simulate arrays using pointers? Illustrate.

UNIT-II

3. a) How to copy and compare structure variables? Illustrate with example.
b) Write and Explain syntax of the following functions: (i) fopen() (ii) fclose() (iii) fread() (iv) fwrite() (v) rewind() (vi)fprintf() (vii) fscanf() (viii) feof().

OR

4. a) Explain the following:
i. Nested structures ii. Array of structures
b) Define union. List out the differences between unions and structures

UNIT-III

5. a) What is Data Structure? Explain in detail about different type of data structures.
b) Write the steps for evaluating postfix expression

OR

6. Show the stack after each operation of the following sequence that starts with the empty stack: push(a), push(b), pop, push(c), push(d), pop.

UNIT-IV

7. What is a Singly Linked List.? Explain different operations of a singly linked list with suitable examples.

OR

8. Write a C function to insert and delete a node from the front end in case of doubly linked list.

UNIT-V

9. Define and describe the terms: Tree, Binary Tree, Complete Binary Tree and Degree of a tree.

OR

10. Define Graph and describe various representations of a graph with suitable examples.

Hall Ticket Number :										
----------------------	--	--	--	--	--	--	--	--	--	--

R-17

Code: 7G321

I B.Tech. II Semester Supplementary Examinations August 2021

Electronic Devices and Circuits

(Common to EEE & ECE)

Max. Marks: 70

Time: 3 Hours

Answer any five full questions by choosing one question from each unit (5x14 = 70 Marks)

UNIT-I

1. a) Illustrate how transistor can be used as an amplifier with neat diagram. 7M
b) Design a self-bias circuit using silicon transistor to achieve a stability factor of 10, with the following specifications: $V_{CC}=16V$, $V_{BE}=0.7V$, $V_{CEQ}=8V$, $I_{CQ}=4\text{ mA}$ & $\beta=50$. 7M

OR

2. a) Explain why operating point is fixed in the center of the active region of transistor characteristics in a good voltage amplifier? Explain the factors which may alter operating point and its effects on performance of an amplifier. 7M
b) What is thermal runaway in transistors? Obtain the condition for thermal stability in transistors. 7M

UNIT-II

3. a) Explain the construction of JFET and its transfer characteristics with neat diagram. 8M
b) Describe the necessary steps for voltage divider bias circuit design. 6M

OR

4. With neat sketches explain construction and operation of EMOSFET. 14M

UNIT-III

5. a) What are the features of ideal amplifier? 7M
b) What are the unique features of CC amplifier circuit? 7M

OR

6. With a neat circuit diagram, explain the working of a transistor amplifier in which phase inversion of the input signal does not take place. Obtain the expressions for such an amplifier. 14M

UNIT-IV

7. Draw the small signal equivalent circuit of FET amplifier in CS connection and derive the equations for voltage gain, input impedance and output impedance. 14M

OR

8. Design a common source FET amplifier circuit with unbypass resistor R_s has $R_d=15k$, $R_s=0.5k$, $R_g=1M$, $r_d=5k$, $g_m=5m$ and $V_{dd}=20V$ 14M

UNIT-V

9. a) Draw the VI characteristics of a tunnel diode and indicate the useful region in the curve. 7M
b) What is the working principle of phototransistor? Explain with necessary diagrams. 7M

OR

10. Discuss the construction, working, characteristics and applications of silicon controlled rectifier. 14M

Hall Ticket Number :

--	--	--	--	--	--	--	--	--	--	--	--	--	--	--	--	--	--	--	--

R-17

Code: 7GC22

I B.Tech. II Semester Supplementary Examinations August 2021

Engineering Chemistry

(Common to EEE & ECE)

Max. Marks: 70

Time: 3 Hours

Answer all five units by choosing one question from each unit (5 x 14 = 70 Marks)

UNIT-I

1. a) What is break point chlorination? State its significance. 7M
b) Write brief account on Priming and foaming. 7M

OR

2. a) What is hardness of water? How do you classify and express hardness? 7M
b) With the help of neat diagram, describe the reverse osmosis method for the desalination of brackish water. 7M

UNIT-II

3. Give reasons for the following
i) Pin holes on tin coated Iron are more prone to corrosion of Iron than those of Zinc coated Iron.
ii) Iron corrodes faster than Aluminium though Al is above Iron in EMF series.
iii) Corrosion of specimen can be controlled by using impressed current 14M

OR

4. Differentiate chemical and electrochemical corrosion 14M

UNIT-III

5. Write a note on processing of raw rubber? Explain the draw backs of raw rubbers. 14M

OR

6. Why silicones are called inorganic polymers? Discuss their synthesis. Write their applications 14M

UNIT-IV

7. a) Write a note on synthesis of petrol by Fischer Tropsch's method. 7M
b) What are the characteristics of a good fuel? 7M

OR

8. a) Write short note on octane number and cetane number. 7M
b) Compare the liquid fuels with gaseous fuels. 7M

UNIT-V

9. a) Describe the analysis of cement 7M
b) Write a note on the classification of refractories with examples. 7M

OR

10. a) Write a note on the composition of Portland cement 8M
b) Explain the importance of refractories and their applications. 6M

Code: 7GC24

I B.Tech. II Semester Supplementary Examinations August 2021

Engineering Mathematics-II

(Common to All Branches)

Max. Marks: 70

Time: 3 Hours

Answer any five full questions by choosing one question from each unit (5x14 = 70 Marks)

UNIT-I

1. a) Trace the curve $y^2(2a - x) = x^2$. 7M
- b) Evaluate the double integral $\iint_R xy \, dx \, dy$ where 'R' is the region bounded by the lines x -axis, the line $y = 2x$ and $y = \frac{x}{4a}$. 7M

OR

2. a) Trace the curve $r^2 = a^2 \cos 2\theta$. 7M
- b) Evaluate $\iint r^3 \, dr \, d\theta$, over area bound between the circles $r = 2 \cos \theta$ and $r = 4 \cos \theta$. 7M

UNIT-II

3. a) Find the Laplace Transform of $t^2 e^{-3t}$. 7M
- b) Find the Laplace Transform of $\frac{\sin 3t \cos t}{t}$. 7M

OR

4. a) Find the Laplace Transform of $\int_0^t \int_0^t \int_0^t \cos au \, du \, du \, du$. 7M
- b) Find the Laplace Transform of $\frac{\cos 2t - \cos 3t}{t}$. 7M

UNIT-III

5. a) Find the inverse transform of $\frac{s^2 - 3s + 4}{s^3}$. 7M
- b) Find the inverse transform of $\frac{1}{s(s^2 + a^2)}$. 7M

OR

6. Using Convolution Theorem, Evaluate $L^{-1} \left\{ \frac{1}{s(s^2 + 2s + 2)} \right\}$. 14M

UNIT-IV

7. a) Find the unit vector normal to the surface $x^3 + y^3 + 3xyz = 3$ at the point $(1, 2, -1)$. 7M
- b) Prove that $\text{div curl } \vec{F} = 0$. 7M

OR

8. Evaluate the line integral of $\int_c (xy + y^2) \, dx + x^2 \, dy$ where 'c' is the square formed by the lines $y = \pm 1$ and $x = \pm 1$. 14M

UNIT-V

9. Verify Gauss Divergence theorem for $\vec{F} = x^3 \vec{i} + y^3 \vec{j} + z^3 \vec{k}$ taken over the cube bounded by $x = 0, x = a; y = 0, y = a; z = 0, z = a$. 14M
- OR
10. Verify Green's Theorem for $\int_c [(3x - 8y^2) \, dx + (4y - 6xy) \, dy]$ where 'c' is bounded by region bounded by $x = 0, y = 0$ and $x + y = 1$. 14M

Code: 7G523

I B.Tech. II Semester Supplementary Examinations August 2021

Geometrical Drawing

(Common to EEE & ECE)

Max. Marks: 70

Time: 3 Hours

Answer any five full questions by choosing one question from each unit (5x14 = 70 Marks)

UNIT-I

1. Draw an epicycloid of a circle of 40mm diameter, which rolls outside on another circle of 120mm diameter for one revolution clockwise. Draw a tangent and a normal to it at a point 95mm from the centre of the directing circle. 14M

OR

2. Construct an ellipse, when the distance of the focus from the directrix is equal to 50mm and eccentricity is $2/3$. Also draw tangent and normal to the curve at a point 40mm from the directrix. 14M

UNIT-II

3. A point 30mm above 'xy' line is the plane view of two points P & Q the elevation of P is 45mm above the H.P. While that of the point Q is 35mm below the H.P. Draw the projections of the points and state their positions with reference to the principal planes on the quadrant in which they lie. 14M

OR

4. A line PQ, 65mm long has its end P is on H.P and 15mm in front of the V.P. The line is inclined at 45° to the H.P and parallel to V.P. Draw the projections. 14M

UNIT-III

5. A square ABCD of 40mm side has a corner on the HP and 20mm in front of the VP. All the sides of the squares are equally inclined to the HP and parallel to the VP. Draw its projections. 14M

OR

6. A regular hexagonal lamina of 22mm side rests on one of its sides on HP. It is parallel to and 15mm away from the VP. Draw its projections. 14M

UNIT-IV

7. A hexagonal pyramid, base 25mm side and axis 50mm long, has an edge of its base on the ground. Its axis is inclined at 30° to the ground and parallel to the VP. Draw its projections. 14M

OR

8. Draw the projections of a cone, base 45mm diameter and axis 80mm lying on the HP on one of its generators with the axis parallel to the VP. 14M

UNIT-V

9. A sphere of 50 mm diameter is resting centrally on the top surface of a square slab of 60mm x 60mm x 20mm height. Draw the isometric view. 14M

OR

10. Convert the following isometric view to orthographic view as shown in Fig.1
(i) Front View (ii) Top View (iii) Right Side View

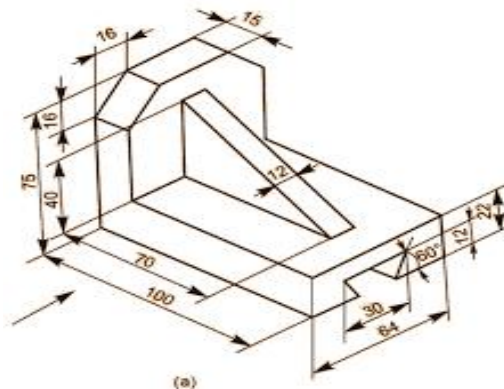

Fig.1 (All dimensions are in 'mm')

14M
