

Hall Ticket Number :

**R-17**

**Code: 7G522**

I B.Tech. II Semester Supplementary Examinations June 2022

**Engineering Mechanics-Dynamics**

(Common to CE & ME)

Max. Marks: 70

Time: 3 Hours

Answer any five full questions by choosing one question from each unit (5x14 = 70 Marks )

\*\*\*\*\*

Marks

**UNIT-I**

1. a) Derive the equations of rectilinear motion of a particle moving with constant acceleration.
- b) A stone is dropped into a well and falls vertically with constant acceleration  $g=9.81 \text{ m/s}^2$ . The sound of impact of the stone is on the bottom of the well is heard 6.5 sec after it is dropped. If the velocity of sound is 336.33 m/s, how deep is the well?

**OR**

2. Motion of a particle is given by the equation  $x=t^3- 3t^2-9t + 12$ . Determine the time, position and acceleration of the particle when its velocity becomes zero.

**UNIT-II**

3. A motor running freely at 1200 rpm is switched off, the deceleration due to bearings varies with time  $= 3t - 4t^2$ . Determine angular velocity and displacement at  $t=3\text{s}$ . Also determine the time taken to stop.

**OR**

4. A flywheel rotating at 300rpm reduces its speed to 240 rpm while making 10 complete revolutions. determine its angular retardation assuming it to be uniform what is its speed after 3 seconds assuming the same retardation? Also, determine how much time is taken to come to a rest from a speed of 300 rpm.

**UNIT-III**

5. A block of 2kg mass rests on a rough horizontal surface, whose coefficient of kinetic friction is 0.2. It is acted on by a horizontal force of 10N for 5 seconds and then it is removed. Determine how far it would travel before coming to rest, assuming the frictional resistance to be uniform. Also, determine the total distance travelled starting from rest.

**OR**

6. Determine the tensions in the strings and accelerations of blocks A and B weighing 150N and 50N connected by a string and a frictionless and weightless pulley as shown in figure.

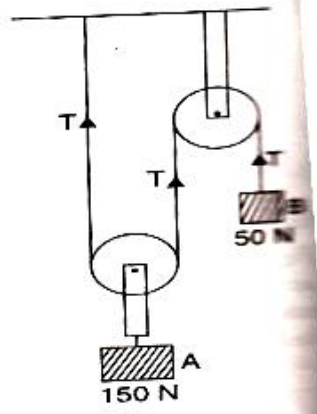

#### UNIT-IV

7. A ball of 50kg mass is dropped from a height of 10m, and after striking the floor it rebounds to a height of 7m. determine i) the impulse of the force, and ii) the average force exerted by the floor on the ball, if the force acts for a fraction  $1/60^{\text{th}}$  of a second.

**OR**

8. A jet of water 6 mm moves at 15 m/s issued from a nozzle strikes normally a smooth fixed plate. The water after striking the plate leaves parallel to the plate. Determine the force exerted by the jet of water on the plate.

#### UNIT-V

9. A flywheel of 5 kg mass and 20 cm radius of gyration is directly coupled to an electric motor, which can develop 10 kw power when rotating at a speed of 1200 rpm. Determine the driving torque to maintain this speed. If power is switched off and the flywheel comes to rest in 10 seconds, determine the uniform retarding torque on the flywheel.

**OR**

10. A constant force of 100N is applied tangentially on a cylinder at rest, whose mass is 50kg and radius is 10cm, for a distance of 5m. Determine the angular velocity of its centre of mass. Assume that there is no slip.

\*\*\*

--	--	--	--	--	--	--	--	--	--

Code: 7GC24

I B.Tech. II Semester Supplementary Examinations June 2022

**Engineering Mathematics-II**

(Common to All Branches)

Max. Marks: 70

Time: 3 Hours

Answer any five full questions by choosing one question from each unit (5x14 = 70 Marks )

\*\*\*\*\*

Marks

**UNIT-I**

1. Evaluate the double integral  $\iint_R xy \, dx \, dy$  where 'R' is the region bounded by the lines

$$x\text{-axis, the line } y = 2x \text{ and } y = \frac{x}{4a}$$

**OR**

2. Evaluate  $\int_0^{\infty} \int_0^{\infty} e^{-(x^2+y^2)} \, dx \, dy$  by changing to polar coordinates.

**UNIT-II**

3. a) Find the Laplace Transform of  $\frac{\cos at - \cos bt}{t}$

- b) Find the Laplace Transform of  $t^2 e^{-3t}$ .

**OR**

4. a) Find the Laplace Transform of  $\sin 2t \sin 3t$

- b) Find the Laplace Transform of  $\frac{\sin 3t \cos t}{t}$

**UNIT-III**

5. Find the inverse transform of  $\log\left(\frac{s+1}{s-1}\right)$ .

**OR**

6. Solve the differential equation  $y'' + y = t$ ,  $y(0) = 1$ ,  $y'(0) = 2$  Using Laplace Transform

**UNIT-IV**

7. Find the unit vector normal to the surface  $x^3 + y^3 + 3xyz = 3$  at the point  $(1, 2, -1)$

**OR**

8. Find  $\operatorname{div} \bar{F}$  and  $\operatorname{curl} \bar{F}$  where  $\bar{F} = \operatorname{grad}(x^3 + y^3 + z^3 - 3xyz)$

**UNIT-V**

9. Evaluate by Green's theorem  $\int_c [(x^2 - \cos hy) \, dx + (y + \sin x) \, dy]$ , where 'c' is the rectangle with vertices  $(0,0)$ ,  $(f,0)$ ,  $(f,1)$ ,  $(0,1)$ .

**OR**

10. Verify Gauss Divergence theorem for  $\bar{F} = x^3 \bar{i} + y^3 \bar{j} + z^3 \bar{k}$  taken over the cube bounded by  $x=0, x=a; y=0, y=a; z=0, z=a$

\*\*\*

Hall Ticket Number :										
----------------------	--	--	--	--	--	--	--	--	--	--

<b>R-17</b>
-------------

**Code: 7GC23**

I B.Tech. II Semester Supplementary Examinations June 2022

### **Engineering Physics**

(Common to CE, ME & CSE)

Max. Marks: 70

Time: 3 Hours

Answer any five full questions by choosing one question from each unit (5x14 = 70 Marks )

\*\*\*\*\*

<b>UNIT-I</b>
---------------

1. Explain the process of induced absorption, spontaneous emission and stimulated emission. Obtain an expression for energy density of radiation under equilibrium conditions in terms of Einstein A & B Coefficients.

**OR**

2. Explain the construction and working of semiconductor laser

<b>UNIT-II</b>
----------------

3. a) What is space lattice? Describe briefly the seven systems of crystals  
b) Explain the various detection methods for ultrasonics.

**OR**

4. Derive Bragg's law for X-ray diffracton

<b>UNIT-III</b>
-----------------

5. Mention the assumptions of classical free electron theory. Based on classical free electron theory derive the expression for electrical conductivity of a metal.

**OR**

6. Explain the salient features of quantum free electron theory.

<b>UNIT-IV</b>
----------------

7. Describe with suitable diagrams the construction and action of a P-N junction diode

**OR**

8. a) Discuss Maglev vehicles and SQUIDS.  
b) What is Meissner effect? Discuss type I and type II superconductor with examples.

<b>UNIT-V</b>
---------------

9. a) Explain in detail any two applications of nanotechnology  
b) Discuss the applications of hard and soft magnets

**OR**

10. a) What are ferromagnetic materials? Discuss the hysteresis of a ferromagnetic material  
b) Explain the synthesis of nanomaterials using chemical vapour deposition.

\*\*\*

Hall Ticket Number :																			
----------------------	--	--	--	--	--	--	--	--	--	--	--	--	--	--	--	--	--	--	--

<b>R-17</b>
-------------

**Code: 7G121**

I B.Tech. II Semester Supplementary Examinations June 2022

**Data Structures**

(Common to All Branches)

Max. Marks: 70

Time: 3 Hours

Answer any five full questions by choosing one question from each unit (5x14 = 70 Marks )

\*\*\*\*\*

Marks

<b>UNIT-I</b>
---------------

1. a) Define pointer? How pointer variables are initialized.
- b) Write a c program to access elements of an array using pointers.

**OR**

2. a) Write a short note on void pointer.
- b) Discuss about any two dynamic memory allocation functions.

<b>UNIT-II</b>
----------------

3. a) Differentiate structures and unions.
- b) Explain any one sorting technique with example program.

**OR**

4. a) List and explain any four functions related to file handling in c.
- b) Differentiate linear search and binary search.

<b>UNIT-III</b>
-----------------

5. What is Queue? Explain the operations of a Queue with an example program.

**OR**

6. a) Convert the following infix expression to post fix expressions  
i)  $A + B * C + D$       ii)  $(A + B) * (C + D)$
- b) What is stack? Write the applications of stack.

<b>UNIT-IV</b>
----------------

7. Discuss the operations of a single linked list with proper diagrams.

**OR**

8. How to represent doubly linked list? Write the algorithm to insert and delete operations in double linked list.

<b>UNIT-V</b>
---------------

9. What is Binary Search Tree? Construct the BST for the nodes 15, 6, 3, 7, 45, 50

**OR**

10. What is Di-graph? Explain different representation of graphs.

\*\*\*

Hall Ticket Number :

--	--	--	--	--	--	--	--	--	--	--

R-17

Code: 7G521

I B.Tech. II Semester Supplementary Examinations June 2022

**Engineering Graphics-II**

(Common to CE & ME)

Max. Marks: 70

Time: 3 Hours

Answer any five full questions by choosing one question from each unit (5x14 = 70 Marks)

\*\*\*\*\*

Marks

**UNIT-I**

1. Draw the projections of a cone, base 75mm diameter and axis 100mm long, lying on the HP on one of its generators with the axis parallel to the VP.

14M

**OR**

2. A thin  $30^{\circ}$ - $60^{\circ}$  set square has its longest edge in the VP and inclined at  $30^{\circ}$  to HP. Its surface makes an angle of  $45^{\circ}$  with the VP. Draw the projections.

14M

**UNIT-II**

3. A pentagonal prism of side of base 30 mm and height 60 mm is resting on HP on its base with one of the edges of the base parallel to V.P. It is cut by a sectional plane which is inclined at  $60^{\circ}$  with H.P. and passing 20 mm below the apex. Draw its sectional front view, top view and true shape of section.

14M

**OR**

4. A square pyramid of the base 40 mm and altitude 70 mm is resting with its base on HP with one of its sides of the base is inclined to VP by  $40^{\circ}$ . It is cut by section plane which is perpendicular to VP and  $40^{\circ}$  to HP. The section plane cut the axis of the pyramid at a height of 50 mm from the base. Draw the sectional top view, front view and true shape of the section.

14M

**UNIT-III**

5. A triangular prism, having base with a 60 mm side and a 100 mm long axis, is resting on its base on the H.P. with a nearer face parallel to the V.P. It is penetrated by a cylinder with a 50 mm diameter and a 90 mm long axis. The axis of the cylinder is parallel to both the reference planes, and 15 mm away from the axis of the prism towards the observer. Draw the projections of the combination and show the curves of intersection.

14M

**OR**

6. A pentagonal prism having a base with 30 mm side and 65 mm long axis, is resting on its base in the H.P. with a rectangular face parallel to the V.P. It is cut by a section plane perpendicular to the V.P., inclined at  $30^\circ$  with the H.P., and passing through a point on the axis, 25 mm from one of the bases. Draw the development of its lateral surface. 14M

**UNIT-IV**

7. Draw the isometric view of a pentagonal prism of base 60mm side, axis 100 mm long and resting on its base with a vertical face perpendicular to V.P. 14M

**OR**

8. A right circular cone of base diameter 60mm and height 75mm is cut by a plane making an angle of  $30^\circ$  with the horizontal. The plane passes through the midpoint of the axis. Draw the isometric view of the truncated solid 14M

**UNIT-V**

9. Draw the front view, top view and right side view for the following figure

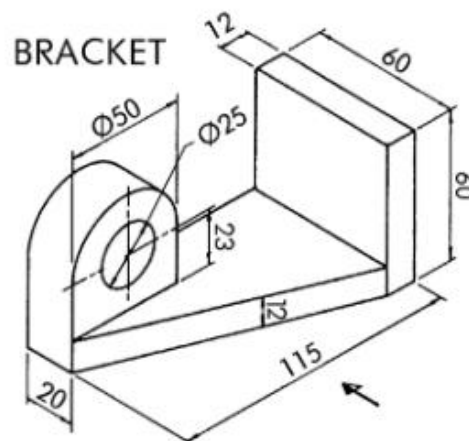

14M

**OR**

10. Draw isometric view for the following orthographic projection.

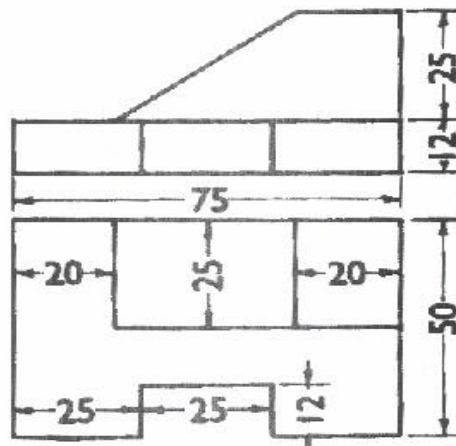

14M

\*\*\*