

Code : 1G513a**ANNAMACHARYA INSTITUTE OF TECHNOLOGY & SCIENCES :: RAJAMPET
(AUTONOMOUS)****B.Tech I Year Regular Examinations, May/June 2012****ENGINEERING DRAWING****(Common to EEE and IT branches)****(For students admitted in 2011-12)****Time: 3 hours****Max Marks: 70***** * * * ****Answer any FIVE of the following**All questions carry equal marks*

1. Construct a parabola when its double ordinate is 150mm and abscissa is 65mm. Find its focus and directrix. Draw a tangent from a point P outside the curve. Point P is 30 mm from the focus and 15 mm from the vertex. 14M
2. A circle of 40 mm diameter rolls on a horizontal line. Draw the curve traced out by a point R on the circumference for one half revolution of the circle. For the remaining half revolution the circle rolls on the vertical line. The point R is vertically above the centre of the circle in the starting position. 14M
3. The end A of a line AB is in the H.P. and 15mm in front of the V.P. The end B is 50mm behind the V.P. and 40mm below the H.P. The distance between the end projectors is 100 mm. Draw the projections of AB and determine its true length 14M
4. Draw the projections of a circular plate, 50mm diameter, resting on the ground on a point A on the circumference, with its plane inclined at 45° to the H.P. and the top view of the diameter AB making an angle of 30° with the V.P. 14M
5. A square prism, side of base 30mm and axis 60mm long, has its axis inclined at 60° to H.P. It has an edge of its base in the H.P. and inclined at 45° to V.P. draw its projections. 14M
6. Draw the isometric view of a pentagonal prism, with side of base 25mm and axis 75mm long. The prism is resting on its base on H.P. with an edge of the base parallel to V.P. 14M

7. Draw the isometric view of Fork shown in two views in figure below.

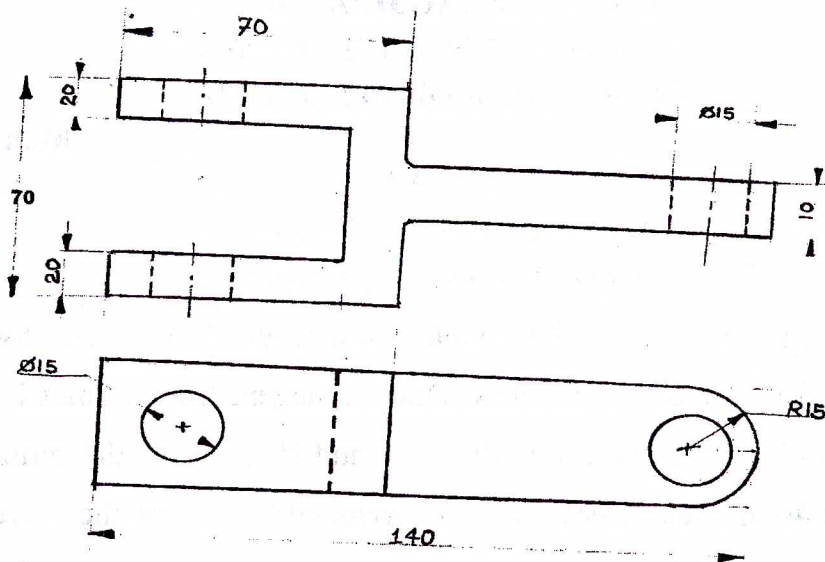

8. Consider the picture shown in figure below and draw the front view, top view and side views in first angle projection.

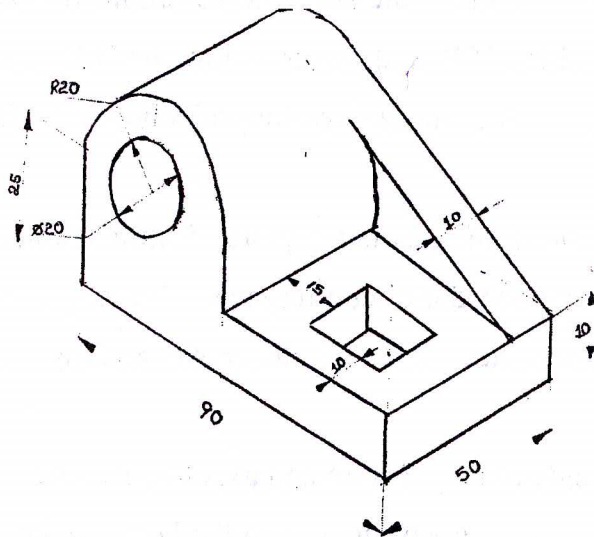

Time: 3 hours

Max Marks: 70

*Answer any FIVE of the following**All questions carry equal marks*

1. a) Two liters of water obtain from well near Tirupati showed the following analysis per liter : $\text{MgSO}_4 = 24\text{mg}$; $\text{Ca}(\text{HCO}_3)_2 = 32.4\text{ mg}$; $\text{Mg}(\text{HCO}_3)_2 = 29.2\text{ mg}$; $\text{CaSO}_4 = 27.2\text{mg}$; suspended matter = 36mg. calculate the temporary, permanent and total hardness of water in ppm units. 8M
- b) Describe the scale and sludge formations in boiler? Explain its drawbacks. 6M
2. a) The resistance of N/2 solution of an electrolyte in a cell was found to be 50 ohm. Calculate the equivalent conductance of the solution, if the electrodes in a cell are 2.2 cm apart with an area of 3.8 sq cm. 7M
- b) What is meant by fuel cell? Explain the Hydrogen-Oxygen fuel cell. 7M
3. a) Explain how heterogeneity of metal increases the rate of corrosion? 6M
- b) Give reasons for the following 8M
 - i) Pin holes on tin coated Iron are more prone to corrosion of Iron than those of Zinc coated Iron.
 - ii) Iron corrode faster than aluminium though 'Al' is above Iron in emf series.
 - iii) Use of dissimilar metals should be avoided.
 - iv) Corrosion of specimen can be controlled by using impressed current.
4. a) How is Bakelite manufactured? Explain its properties and applications. 7M
- b) Distinguish between thermoplastic and thermosetting resins with suitable examples. 7M
5. a) Define an explosive? How are they classified? Criteria for a good explosive. 7M
- b) Write short notes on 7M
 - i) Dynamite
 - ii) TNT

6. a) For one component system, the triple point is an invariant system? Discuss. 7M
b) Determine the number of phases, components and degree of freedom in the system ice, water and water vapour in equilibrium. 7M
7. a) What are chemical fuels? Give their classification with examples. 6M
b) An oil analysis gave the following results? C:85% ; H=12% and O=3%. Find the weight required for minimum air for burning of 1 Kg of the fuel. 8M
8. a) What is meant by setting and hardening of cement? Explain with chemical reactions. 7M
b) Write briefly causes for the failure of a refractory material. 7M

* * *

Code : 1GC12

ANNAMACHARYA INSTITUTE OF TECHNOLOGY & SCIENCES :: RAJAMPET
(AUTONOMOUS)

B.Tech I Year Regular Examinations, May/June 2012

ENGINEERING PHYSICS

(Common to All Branches)

(For students admitted in 2011-12)

Time: 3 hours

Max Marks: 70

* * * * *

Answer any FIVE of the following

All questions carry equal marks

1. a) Mention necessary conditions to obtain Interference of light. 3M
- b) Describe the theory and the experimental procedure to determine the wave length of light source by forming Newton's rings. 7M
- c) In Newton's rings experiment the diameter of 5th ring is reduced to three fourths of its initial value after introducing a liquid below the convex surface. Calculate the refractive index of the liquid. 4M
2. a) Describe the seven crystal systems based on the lattice parameters. 7M
- b) Show that, FCC is the most closely packed of three basic cubic structures by working out the packing factors. 7M
3. a) State and explain deBroglie's hypothesis of matter Waves. 3M
- b) Discuss the motion of an electron in a periodic potential field using Kronig-Penney Model. 7M
- c) An electron is bound in one dimensional potential box of width 1×10^{-10} m. Find its energy in the ground state.
Given planck's constant = 6.626×10^{-34} J – sec⁻¹
and mass of electron = 9.1×10^{-31} kg. 4M
4. a) Explain drift and diffusion in a semiconductor. 5M
- b) Derive Einstein's relation for charge carriers in a semiconductor. 5M
- c) Explain diode current equation. 4M
5. a) Show that ionic polarization of a dielectric is independent of temperature. 4M
- b) Explain the origin of orbital magnetic moment in an atom. 6M
- c) Explain the ferroelectric behavior of Barium Titanate (BaTiO₃) 4M

6. a) State and explain Meissner effect in super conductors. 4M
- b) Describe the construction and working principle of He-Ne laser. 7M
- c) Mention the important applications of super conductors. 3M
7. a) Explain the various types of optical fibers based on their refractive index profiles and light propagation. 4M
- b) Describe the working of optical fiber communication system with a neat diagram. 6M
- c) Explain the construction and reconstruction of hologram. 4M
8. a) Explain the basic fabrication methods of nano materials 4M
- b) What is carbon nano tubes? Describe the various types of carbon nano tubes along with its properties. 10M

* * *

Code : 1GC11**ANNAMACHARYA INSTITUTE OF TECHNOLOGY & SCIENCES :: RAJAMPET
(AUTONOMOUS)****B.Tech I Year Regular Examinations, May/June 2012****ENGLISH****(Common to All Branches)****(For students admitted in 2011-12)****Time: 3 hours****Max Marks: 70***** * * * ***

*Answer any FIVE of the following
All questions carry equal marks*

1. "Inevitably, Ladakh is something of a test case of what good as well as bad can be brought by travelers". Elaborate.
2. a) Write about the early hood and education of Visvesvaraya.
b) Why did Mother Teresa shifted her service from God to the poor and the needy?
3. a) Did Miss. Krishna make a good Guest? Give reasons for your answer.
b) Why was the day when Raman walked into the IACS a historic moment?
4. a) According to Satyajit Ray, what are the three factors that should guide a director when he/she chooses a story for a film?
b) How does Ray describe the films that are commonly made in India?
5. a) How did Vikram Sarabhai setup physical research Laboratory?
b) What is the unique feature of new communication network systems developed by Sam Pitroda?
6. How did Anand become a great chess champion? What are the distinctions that Anand achieved?
7. a) Imagine that you are the assistant Medical officer, District Health Center, Chittoor (Dt). It has been noticed that dengue fever has spread over the district recently. Around 40 dengue cases have been found out of which 6 were died. Hence, you have been directed by the Chief Medical officer of the same district to conduct a survey to get accurate data and to suggest some ways and means to control the dengue virus. Write a report stating all the above mentioned and submit it for its kind perusal.
b) Write a letter to the Principal of your college to arrange for a reading room in the library and also sports and games.

8. a) Correct the following sentences :

- i) She went out without some money.
- ii) I am suffering with fever now.
- iii) Sarala has seen a movie last week.
- iv) Speak fluently English.
- v) Bread and butter are my food.

b) Write meanings for the following idioms :

- i) flash on pan.
- ii) once in a blue moon.
- iii) a bolt from the blue.
- iv) in leaps and bounds.
- v) by hook or by crook.

c) Give one word substitute for the following :

- i) belief that there is no god.
- ii) person who is expert in taste.
- iii) a doctor who treats the ailments of heart.
- iv) Fear of animals.

* * *

Code : 1GC15

ANNAMACHARYA INSTITUTE OF TECHNOLOGY & SCIENCES :: RAJAMPET
(AUTONOMOUS)

B.Tech I Year Regular Examinations, May/June 2012

MATHEMATICAL METHODS

(Common to CSE and IT Branches)

(For students admitted in 2011-12)

Time: 3 hours

Max Marks: 70

* * * * *

Answer any FIVE of the following

All questions carry equal marks

1. a) Find the rank of the matrix A by reducing it to the normal form where

$$A = \begin{bmatrix} 1 & 1 & 1 & 1 \\ 1 & 2 & 3 & -4 \\ 2 & 3 & 5 & -5 \\ 3 & -4 & -5 & 8 \end{bmatrix}$$

- b) Test for consistency the set of equations and solve them if they are consistent.

$$x + 2y + 2z = 2, 3x - 2y - z = 5, 2x - 5y + 3z = -4, x + 4y + 6z = 0$$

2. a) Find the characteristic roots of the matrix $\begin{bmatrix} 6 & -2 & 2 \\ -2 & 3 & -1 \\ 2 & -1 & 3 \end{bmatrix}$ and corresponding

Eigen vectors.

- b) Using Caley-Hamilton theorem find the inverse and A^4 of the matrix

$$A = \begin{bmatrix} 7 & 2 & -2 \\ -6 & -1 & 2 \\ 6 & 2 & -1 \end{bmatrix}$$

- 3 Reduce the quadratic form : $3x^2 + 5y^2 + 3z^2 - 2yz + 2zx - 2xy$ to the canonical form. Also specify the matrix of transformation.

4. a) Find a root of $e^x \sin x = 1$ using Newton Raphson method.

- b) The population of a town in the decadal census was given below. Estimate the population for the year 1895.

Year x	1891	1901	1911	1921	1931
Population y (Thousands)	46	66	81	93	101

5. a) Fit a second degree polynomial to the following data by the method of least squares.

x	0	1	2	3	4
y	1	1.8	1.3	2.5	6.3

- b) Fit the curve $y = a e^{bx}$ to the following data

x	0	1	2	3	4	5	6	7	8
y	20	30	52	77	135	211	326	550	1052

6. a) Using the following data find x for which y is minimum and find this value of y.

x	0	2	4	6
y	3	3	11	27

- b) Evaluate $\int_0^1 \frac{dx}{1+x^2}$ using $\frac{3}{8}$ rule of Simpson taking $h = \frac{1}{6}$. Hence obtain an

approximate value of π .

7. a) Using Euler's method solve for y at x=2 from $\frac{dy}{dx} = 3x^2 + 1, y(1) = 2$ taking step size i) h=0.5 ii) h=0.25

- b) Using Runge-Kutta method of order 4, compute y(2.5) for the equation $\frac{dy}{dx} = \frac{x+y}{x}, y(2) = 2$.

8. a) Express $f(x) = x - \pi$ as Fourier Series in the interval $-\pi < x < \pi$.
 b) Find the half range Cosine and Sine series for the function $f(x) = x$ in the range $0 \leq x \leq \pi$.

Code : 1GC14

ANNAMACHARYA INSTITUTE OF TECHNOLOGY & SCIENCES :: RAJAMPET
(AUTONOMOUS)

B.Tech I Year Regular Examinations, May/June 2012

MATHEMATICS-I

(Common to All Branches)

(For students admitted in 2011-12)

Time: 3 hours

Max Marks: 70

*Answer any FIVE of the following
All questions carry equal marks*

1. a) Solve $\left(1 + e^{\frac{x}{y}}\right) dx + e^{\frac{x}{y}} \left(1 - \frac{x}{y}\right) dy = 0$
- b) Find the orthogonal Trajectories of the family of cardioids $r = a(1 - \cos \theta)$ where a is the parameter.
- c) A body is kept in air with temperature 25° C cools from 140° to 80° C in 20 minutes. Find when the body cools down to 35° C.
2. a) Solve $(D^2 + 3D + 2) y = e^{-x} + x^2 + \cos x$
- b) Solve by method of variation of parameters $(D^2 + 1) y = x \cos x$
3. a) Verify Rolle's theorem for $f(x) = 2x^3 + x^2 - 4x - 2$ in $[-\sqrt{2}, \sqrt{2}]$.
- b) Find the extreme values of $f(x, y) = x^2y^2 - 5x^2 - 8xy - 5y^2$
4. a) Trace the curve $y^2(a + x) = x^2(3a - x)$
- b) The part of the parabola cut off by the latus rectum is rotated (i) about the latus rectum (ii) about the axis. Show that the volumes generated are in the ratio 16:15
5. a) Evaluate $\int_0^1 \int_0^{1-z} \int_0^{1-y-z} xyz \, dx dy dz$
- b) Evaluate the integral by changing the order of integration
$$\int_0^a \int_{x/a}^{\sqrt{x/a}} (x^2 + y^2) dx dy$$
6. a) Find the Laplace Transform of $\left\{\left(\sqrt{t} + \frac{1}{\sqrt{t}}\right)^3\right\}$
- b) Find $L^{-1} \left[\frac{s}{(s^2+1)(s^2+9)(s^2+25)} \right]$
7. Solve the differential equation $y^{ii} + y = t, y(0) = 1, y'(0) = 2$ using Laplace transform.
8. Verify Stokes theorem for $F = (x^2 - y^2)i + 2xyj$ over the box bounded by the planes $x=0, x=a, y=0, y=b$.

Code : 1G111**ANNAMACHARYA INSTITUTE OF TECHNOLOGY & SCIENCES :: RAJAMPET
(AUTONOMOUS)****B.Tech I Year Regular Examinations, May/June 2012
PROGRAMMING IN C AND DATA STRUCTURES****(Common to CSE and IT branches)
(For students admitted in 2011-12)****Time: 3 hours****Max Marks: 70***** * * * ****Answer any FIVE of the following
All questions carry equal marks*

1. a) Define Flowchart and Algorithm? Explain the different symbols in flowchart.
b) What are the different stages in program development? Explain.
2. How to control the flow of execution of statements? Explain briefly with suitable examples.
3. a) Define an Array? How they are declared and initialized.
b) Write a program to perform matrix multiplication using arrays and functions.
4. a) What is pointer? Define pointer to pointer?
b) Explain the dynamic memory allocation functions with suitable examples?
5. a) Compare and contrast between structures and unions.
b) Define i) Self Referential structures.
ii) Array of structures.
6. a) What is Queue? Explain the implementation of queues?
b) Write short notes on circular queues?
7. Define a Linked List? What are the ways to implement lists? Explain Insertion and Deletion operations?
8. Compare the sorting techniques of Selection, Bubble and Insertion sorts in terms of their efficiencies? Explain briefly?

*** * ***