

Hall Ticket Number :

--	--	--	--	--	--	--	--	--	--	--

R-11/R-13

Code: 1GC12

B.Tech. I Year Supplementary Examinations Nov/Dec 2016

Engineering Physics

(Common to All Branches)

Max. Marks: 70

Time: 3 Hours

Answer any **five** questions

All Questions carry equal Marks (**14 Marks** each)

1. a) Distinguish between interference and diffraction of light. 3M
b) Explain the formation of Newton's rings with necessary theory. 8M
c) Find the thickness of half wave plate for a light beam of wavelength 600nm, if the difference in the refractive indices of E and O rays is 0.125. 3M
2. a) State and explain Bragg's Law for X-ray diffraction. 4M
b) Describe the basic crystal systems based on lattice parameters 7M
c) Find the maximum wavelength of X-rays which can be diffracted by a crystal with interplanar spacing of 2.5\AA in first order diffraction. 3M
3. a) Define Heisenberg's uncertainty principal. 2M
b) Derive Schrodinger's one dimensional time independent wave equation for a free particle. 8M
c) Explain various sources of electrical resistance in the case of metals. 4M
4. a) Distinguish between drift and diffusion of charge carriers in a semiconductor. 3M
b) Explain the formation of p-n junction in a semiconductor with necessary theory. 7M
c) Explain the construction and working principle of LED. 4M
5. a) What are soft and hard magnetic materials. 3M
b) Derive Clausius-Mosotti relation for a polarized dielectric. 7M
c) Explain the concept of hysteresis for ferromagnetic material. 4M
6. a) Mention the significance of penetration depth on superconductor. 3M
b) Describe the construction and working of He-Ne laser with neat diagrams 7M
c) Explain BCS theory of superconductivity. 4M
7. a) Describe graded index optical fiber along with its refractive index profile. 4M
b) Describe the various important components of optical fiber communication system. 7M
c) Mention the important applications of holography. 3M
8. a) Explain the basic principal factors influencing nanomaterial Properties. 4M
b) Describe Sol-Gel method of synthesis of nanomaterials. 6M
c) Mention the significant properties of Carbon nanotubes. 4M

Code: 1G511

B.Tech. I Year Supplementary Examinations Nov/Dec 2016

Engineering Mechanics

(Common to CE and ME)

Max. Marks: 70

Time: 3 Hours

Answer any **five** questionsAll Questions carry equal Marks (**14 Marks** each)

1. a) Define Free Body Diagram and give the steps involved in drawing Free Body Diagram. 7M
 b) Find the Resultant of given force system shown in fig.1 below.

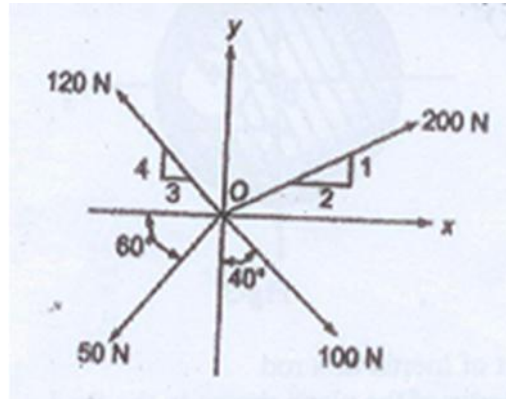

Fig.1

7M

2. Two beams AB and DE are arranged and supported as shown in figure.2. Find the magnitude of the reaction R_E at E due to the force $P=890\text{N}$ applied at B as shown.

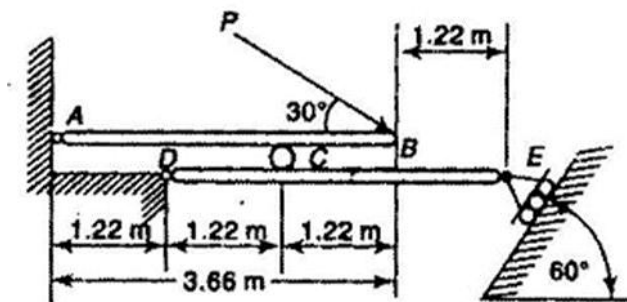

Fig.2

14M

3. a) What is the difference between a Truss and Frame? Write down the basic assumptions for finding forces in members of a perfect frame. 7M
 b) In figure (3), a frame supports a weight of 1 kN. Find the compressive force in the bar DC and the shear force on pin B. The radius of the pulley is 1m.

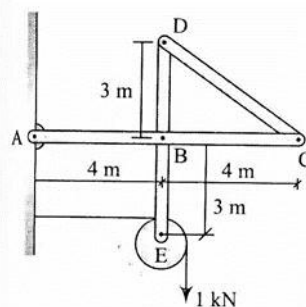

Fig.3

7M

4. a) State the laws of coulomb friction and give the difference between angle of friction and angle of repose. 7M
- b) Two blocks connected by a horizontal link AB are supported on two rough planes as shown in Fig.4. The coefficient of friction for block A on the horizontal plane is $\mu=0.4$. The angle of friction for block B on the inclined plane is $\phi = 15^\circ$. What is the smallest weight W of block A for which equilibrium of the system can exist?

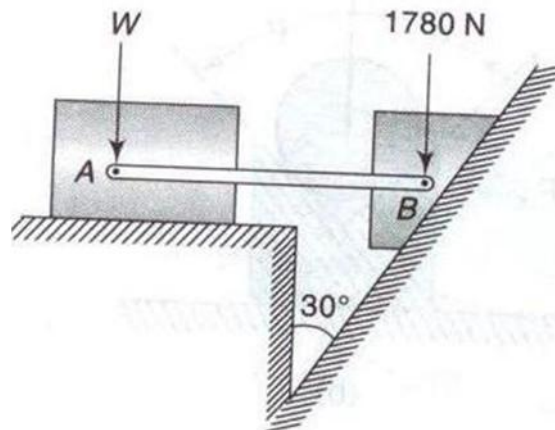

Fig.4

7M

5. a) State and Prove theorems of Pappus. 7M
- b) Reference to Fig.5, determine the coordinates x_c and y_c of the center of a 100 mm diameter, circular hole cut in a thin plate so that this point will be the centroid of the remaining shaded area.

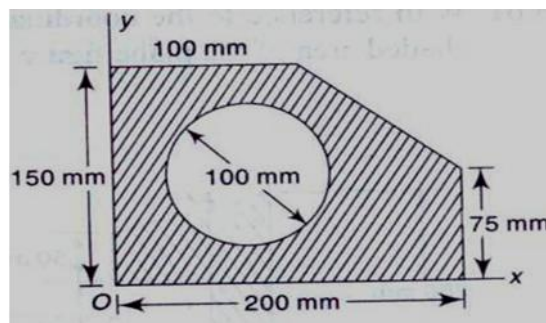

Fig.5

7M

6. a) State and Prove parallel axis theorem. 7M
- b) Reference to Fig.6, Calculate the moment of inertia of the shaded area with respect to a centroidal axis parallel to the x-axis.

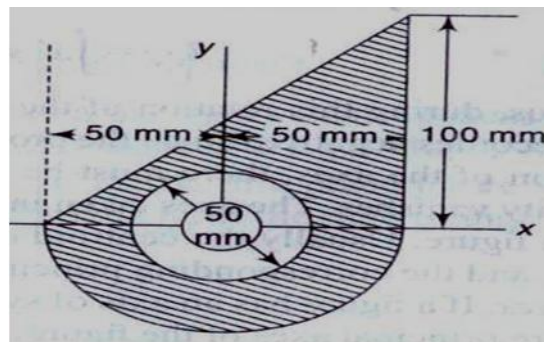

Fig.6

7M

7. a) Derive from fundamentals, all the three kinematic equations of linear motion having constant acceleration. 7M
- b) The motion of a particle is described by the following equations: $x=t^2+8t+4$ and $y = t^3+3t^2+8t+4$. Determine the (i) initial velocity of the particle, (ii) velocity of the particle at $t=2$ seconds and (iii) acceleration of the particle at $t=3$ sec. 7M
8. a) Derive the relation between impulse and linear momentum. 7M
- b) A car of mass 1000 kg descends a hill of $\sin^{-1}(1/6)$. The frictional resistance to motion is 200 N. Calculate, using work energy method, the average braking effort to bring the car to rest from 48 km/h in 30 m. 7M

--	--	--	--	--	--	--	--	--	--	--	--	--	--	--	--	--	--	--	--

Code: 1GC13

B.Tech. I Year Supplementary Examinations Nov/Dec 2016

Engineering Chemistry

(Common to All Branches)

Max. Marks: 70

Time: 3 Hours

Answer any **five** questionsAll Questions carry equal Marks (**14 Marks** each)

1. a) Discuss, in brief, the boiler corrosion. How is it controlled? 6M
 b) Write short notes on
 (i) Phosphate Conditioning
 (ii) ion-exchange process 8M
2. a) Calculate the emf of the cell : Ni / Ni²⁺ (IM) // Pb²⁺ (IM) / Pb at 25°C. Write down its cell reactions. Standard electrode potential of nickel and lead are -0.24 V and -0.13 V respectively at 25°C. 7M
 b) What are insulators? Give the various engineering applications of insulators. 7M
3. a) Discuss the role of nature of oxide layer formed in oxidation corrosion. State and explain Pilling – Bed worth Rule. 8M
 b) Give reasons for the following :
 (i) Corrosion of water-filled tank occurs below the waterline
 (ii) A Copper equipment should not possess a small Steel bolt 6M
4. a) Differentiate between addition polymerization and condensation polymerization with suitable examples. 6M
 b) Describe the method of preparation, properties and applications of the following
 (i) Bakelite 8M
 (ii) Nitrile Rubber
5. a) What are explosives? Explain the manufacture and applications of dynamite. 6M
 b) What is meant by lubricant? Explain the properties of lubricants such as viscosity and aniline point. 8M
6. a) Draw a neat labelled phase diagram of water system and explain areas, curves and triple point in it. 8M
 b) Define the terms : Phase, Component and Degree of freedom used in phase rule. 6M
7. a) Describe, in brief, the manufacture of metallurgical coke by Otto Hoffman's oven method. 7M
 b) Calculate the minimum weight of air required for complete combustion of 1 kg of fuel containing : C = 90 %, H = 3.5 %, O = 3.0 %, S = 0.5 %, H₂O = 1.0 %, N = 0.5% and ash = rest. 7M
8. a) What is a refractory material? Write a detail note on acid and basic refractories and their uses. 7M
 b) Write the chemical reactions that take place during setting cement and explain. 7M

Hall Ticket Number :										
----------------------	--	--	--	--	--	--	--	--	--	--

R-11/R-13

Code: IGC14

B.Tech. I Year Supplementary Examinations Nov/Dec 2016

Mathematics-I

(Common to All Branches)

Max. Marks: 70

Time: 3 Hours

Answer any **five** questions
All Questions carry equal Marks (**14 Marks** each)

1. a) Solve the differential equation $x \frac{dy}{dx} + y = x^3 y^6$ 4M
- b) Find the equation of the system of orthogonal trajectories to the family of curves $r^n \sin n\theta = a^n$, where a is parameter 4M
- c) The temperature of a body drops from 100°C to 75°C in ten minutes when the surrounding air is at 20°C . What will be the temperature after half an hour? When will, the temperature be 25°C 6M
2. a) Solve the differential equation $(D^3 + 2D^2 + D)y = e^{2x} + x^2 + x + \sin 2x$ 7M
- b) Solve by the method of variation of parameters, $(D^2 - 2D)y = e^x \sin x$ 7M
3. a) If $a < b$, prove that $\frac{b-a}{1+b^2} < \tan^{-1} b - \tan^{-1} a < \frac{b-a}{1+a^2}$ using Lagrange's mean value theorem and hence deduce that $\frac{f}{4} + \frac{3}{25} < \tan^{-1} \frac{4}{3} < \frac{f}{4} + \frac{1}{6}$ 7M
- b) A rectangular box open at the top is to have a volume of 32 cubic feet. Find the dimensions of the box requiring least material for its construction. 7M
4. a) Trace the curve, $a^2 y^2 = x^2 (a^2 - x^2)$ 7M
- b) Find the volume formed by the revolution of the loop of the curve $y^2 (a+x) = x^2 (3a - x)$ about the x -axis. 7M
5. a) Evaluate $\iint_R xy \, dx \, dy$ where R is the region bounded by x -axis, ordinate $x = 2a$, and the curve $x^2 = 4ay$ 7M
- b) By changing the order of integration, evaluate $\int_0^3 \int_1^{\sqrt{4-y}} (x+y) \, dx \, dy$ 7M
6. a) Obtain the Laplace transform of the function $f(t) = \begin{cases} (t-1)^2, & t > 1 \\ 0, & 0 < t < 1 \end{cases}$ 7M
- b) Using convolution theorem, evaluate $L^{-1} \left\{ \frac{1}{s(s^2 + 2s + 2)} \right\}$ 7M
7. Solve the differential equation $\frac{d^2x}{dt^2} - 4 \frac{dx}{dt} - 12x = e^{3t}$ given that $x(0) = 1$ and $x'(0) = -2$ using Laplace transforms 14M
8. a) Using line integral, calculate the work done by the force, $\vec{F} = (3x^2 - 6yz)\vec{i} + (2y + 3xz)\vec{j} + (1 - 4xyz^2)\vec{k}$ in moving a particle from the point $(0,0,0)$ to the point $(1,1,1)$ along the curve $C : x = t, y = t^2, z = t^3$ 7M
- b) Verify greens theorem in the plane for $\oint_C (3x^2 - 8y^2) \, dx + (4y - 6xy) \, dy$ where C is the region bounded by $y = \sqrt{x}$ and $y = x^2$ 7M

Hall Ticket Number :										
----------------------	--	--	--	--	--	--	--	--	--	--

R-11/R-13

Code : 1G112

B.Tech. I Year Supplementary Examinations Nov/Dec 2016

C Programming and Introduction to Data Structures

(Common to CE, EEE, ME & ECE)

Max. Marks: 70

Time: 03 Hours

Answer any **five** questions

All Questions carry equal marks (14 Marks each)

1. a) Explain SDLC process and need of it. 8M
b) Write an algorithm for finding the greatest number among three numbers 6M

2. a) List the different data types along with memory occupations in C with suitable example. 8M
b) Explain for loop and nested for loop with suitable example. 6M

3. a) Write a program to read array of numbers and compute sum and average of the numbers. 6M
b) Define an Array? What are different types of Arrays explain? 8M

4. Write about String manipulations functions available in C with examples. 14M

5. a) Distinguish between array of Structures and an array within structures with an example. 8M
b) Define Structure and write general format for declaring and accessing structure members. 6M

6. a) Explain about defining, opening and closing of a file. 9M
b) Write a C program to print "Message" using command line arguments. 5M

7. Define Queue and explain Queue implementation using arrays 14M

8. a) Write a C program to search an element using binary search 7M
b) Explain in detail about insertion sort. 7M

Code: 1G512

B.Tech. I Year Supplementary Examinations Nov/Dec 2016

Engineering Graphics
(Common to CE & ME)

Max. Marks: 70

Time: 3 Hours

Answer any **five** questions
All Questions carry equal Marks (**14 Marks** each)

1. a) Construct a parabola by rectangle method with the base dimension 140 mm and height 100 mm. And also draw the tangent and normal to the parabola at any suitable point 7M
- b) A string is unwound from a circle of 30 mm radius. Draw the locus or Involute of circle of the end of the string for unwinding the string completely. String is kept tight while being unwound. 7M
2. a) Draw the projections of a 65mm long straight line, in the following positions : 5M
 - i. Parallel to both the H.P and the V.P and 25mm from each.
 - ii. Perpendicular to the H.P in the V.P and its one end in the H.P.
- b) The top view of a 75mm long line AB measures 65mm, while the length of its front view is 50mm. Its one end A is in the H.P. and 12mm in front of the V.P. Draw the projections of AB and determine its inclinations with the H.P. and the V.P. 9M
3. a) A regular pentagon of 25mm side has one side on the ground. Its plane is inclined at 45° to the H.P. and perpendicular to the V.P. Draw its projections. 7M
- b) Draw the projections of a circle of 5cm diameter, having its plane vertical and inclined at 30° to the V.P. Its centre is 3cm above the H.P. and 2cm in front of the V.P 7M
4. a) A pentagonal pyramid, base 25mm side and axis 50mm long has one of its triangular faces in the V.P. and the edge of the base contained by that face makes an angle of 30° with the H.P. Draw its projections. 9M
- b) A cube of 40mm side rests with one of its square faces on the H.P. such that one of its vertical faces is perpendicular to V.P. Draw its projections. The nearest edge parallel to V.P. is 5mm in front of it. 5M
5. A cube of side 30mm rests on the HP on its end with the vertical faces equally inclined to the VP. It is cut by a plane perpendicular to the VP and inclined at 30° to the HP meeting the axis at 25mm above the HP. Draw its top view, sectional front view and true shape of the section. 14M
6. Draw the isometric view of the block, two views of which are shown in figure. (All dimensions are in mm). 14M

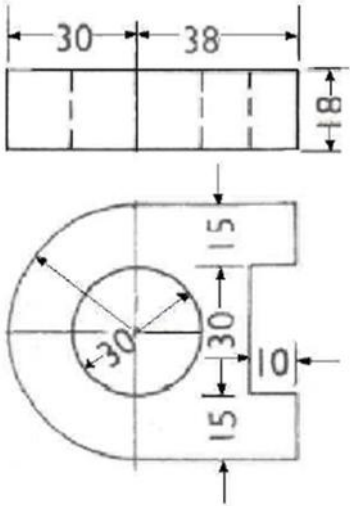

7. A vertical square prism base 50mm side is completely penetrated by a horizontal square prism, base 35mm side, so that their axes intersect. The axis of the horizontal prism is parallel to the V.P., while the faces of the two prisms are equally inclined to the V.P. Draw the projections of the solid showing lines of intersections. (Assume suitable lengths for prism) 14M
8. A rectangular pyramid of base 70 mm X 50 mm and altitude of 70 mm rests with its base on the ground. One corner of the base is 20 mm to the left of the eye and in PP. The 70mm long side of the base recedes to the right at 40°. The eye is 190 mm from PP and 130mm above the ground plane. Draw the perspective view of the pyramid. 14M
