

Hall Ticket Number :

--	--	--	--	--	--	--	--	--	--	--

**R-17**

**Code: 7G535**

II B.Tech. I Semester Supplementary Examinations May 2019

**Machine Drawing**

( Mechanical Engineering )

Max. Marks: 70

Time: 4 Hours

**Part-I**

**Answer any Two questions from the following ( 2 x 10 = 20 Marks )**

1. a) Sketch the following thread profiles for a nominal diameter of 20 mm and pitch 2 mm  
i) Worm thread ii) ACME thread
- b) Sketch the following  
(i) Castle nut (ii) Lock nut (iii) Square nut

**OR**

2. Represent two views of hexagonal nut and square nut with proportions and take the diameter of the bolt as 30 mm
3. Draw a proportionate diagram of Double riveted double strap chain type butt joint two connect plate of 20 mm size.

**OR**

4. Draw
  - a) sectional view from the front and
  - b) view from the side of a universal coupling, indicating proportions, to connect two shafts, each of diameter 40 mm.

## Part-II

Answer any One question from the following ( 1 x 25 = 25 Marks )

5. Assemble all parts of the stuffing box for a vertical steam engine, shown in below figure and draw,
- half sectional view from the front, with left half in section,
  - half sectional view from the right and
  - view from above.

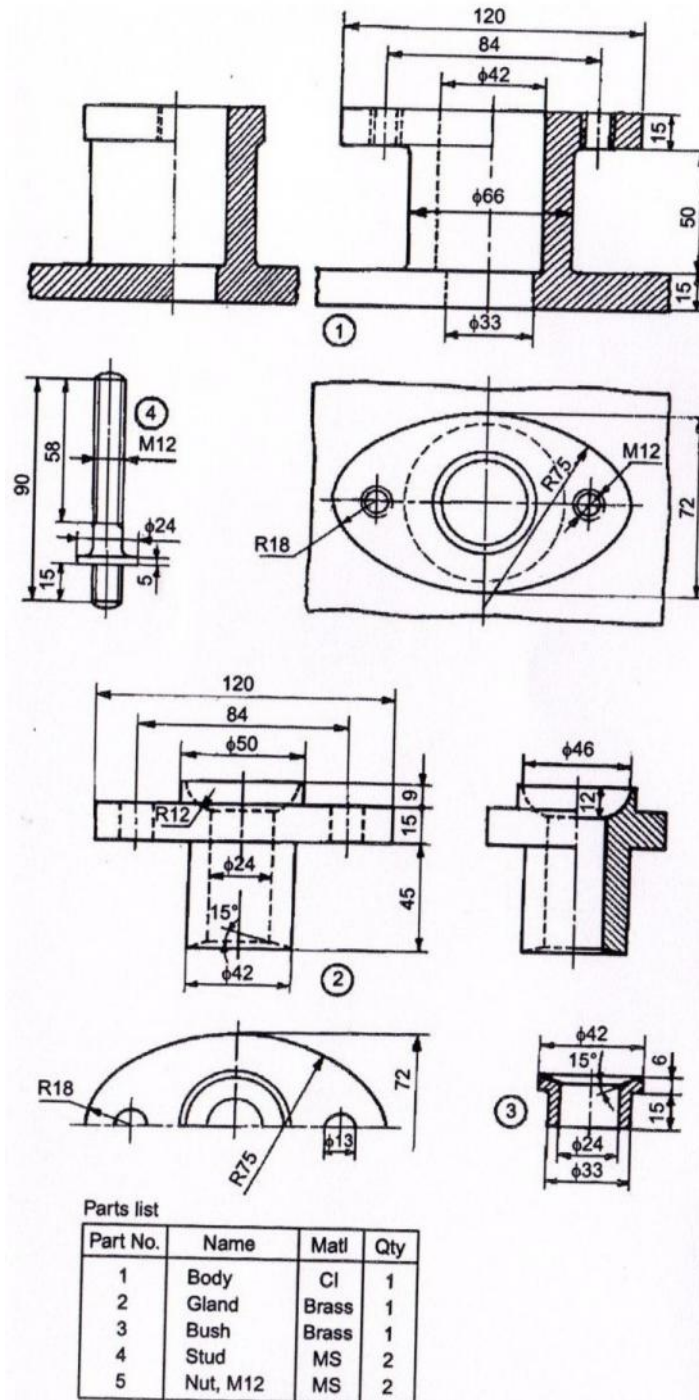

stuffing box

OR

6. The details of an eccentric are shown in below figure. Assemble the parts and draw,  
 (i) half sectional view from the front, with top half in section,  
 (ii) view from the right and  
 (iii) view from above.

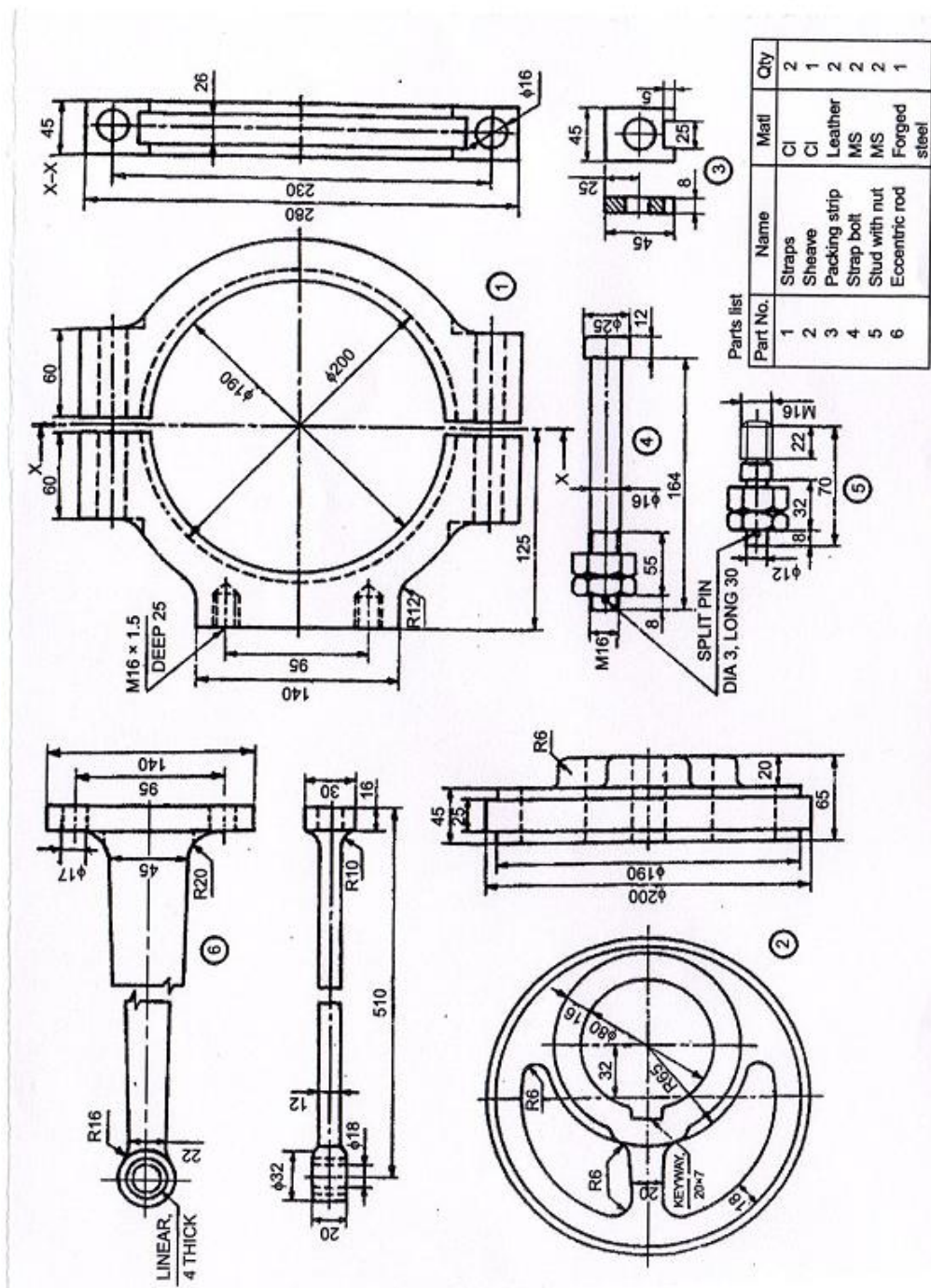

Eccentric

Part-III

Answer any One question from the following ( 1 x 25 = 25 Marks )

7. Prepare the part drawings of the Tool post, shown in below figure

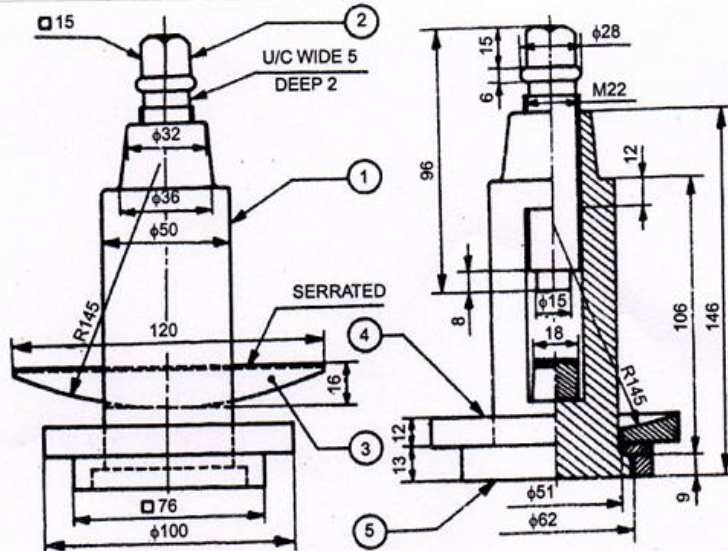

Parts list

Part No.	Name	Matl.	Qty.
1	Body	MS	1
2	Clamp screw	MCS	1
3	Wedge	CI	1
4	Ring	MS	1
5	Square block	MS	1

Tool post

OR

8. Prepare the part drawings of the Plummer block, shown in below figure

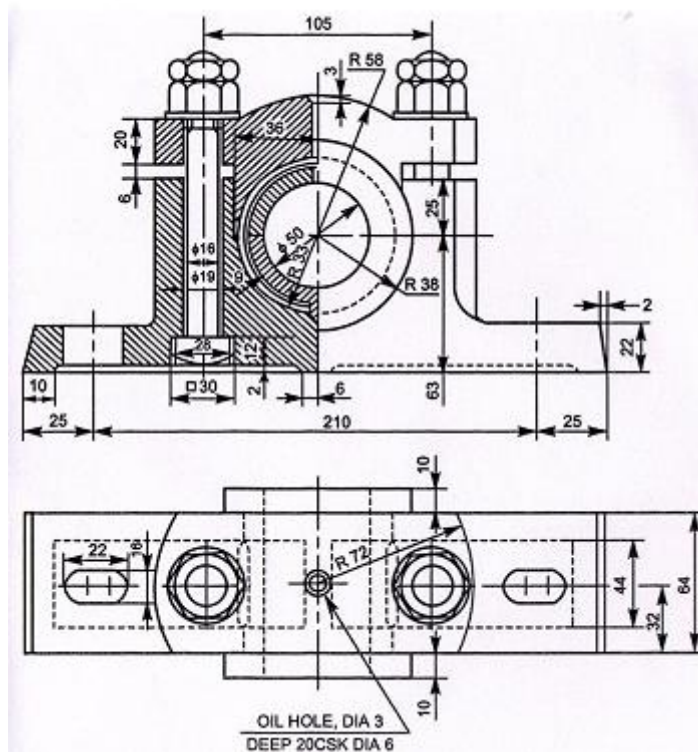

Plummer block

Parts List:

S.No.	Name	Material	Quantity
1	Base	CI	1
2	Bearing Brass	Bronze	1
3	Bearing Brass	Bronze	1
4	Cap	CI	1
5	Bolt with Nuts	MS	2

**Code: 7G534**

II B.Tech. I Semester Supplementary Examinations May 2019

**Manufacturing Technology**

( Mechanical Engineering )

Max. Marks: 70

Time: 3 Hours

Answer *all five* units by choosing one question from each unit ( 5 x 14 = 70 Marks )

\*\*\*\*\*

**UNIT-I**

1. a) What type of allowances is generally incorporated into a casting pattern? Explain 7M  
b) Draw the schematic sketch of Gating system for casting. Mention the working function of each gating system elements. 7M

**OR**

2. a) What is a pattern? Explain the following patterns with a neat diagrams:  
i. Gated pattern.  
ii. Follow board pattern.  
iii. Split piece pattern. 7M  
b) Describe the general design considerations pertaining to metal casting. 7M

**UNIT-II**

3. a) Explain in detail the Plasma Arc Welding process and write its applications and demerits. 7M  
b) Describe with neat sketch the various components of Oxy Acetylene gas welding equipment and explain the welding process. 7M

**OR**

4. a) Explain the working principle of resistance welding process and write its applications. 7M  
b) Distinguish between MIG and TIG Welding. 7M

**UNIT-III**

5. a) With the help of a neat sketch explain the process of tube drawing of metals. 7M  
b) An annealed copper strip 228 mm wide and 25 mm thick is rolled to a thickness of 20 mm in one pass. The roll radius is 300 mm, and the rolls rotate at 100 rpm. Calculate the roll force and the power required in this operation. 7M

**OR**

6. a) Write a short note on the following:  
i. Stamping.  
ii. Blanking.  
iii. Bending. 7M  
b) With a neat sketch, explain the principle of rolling. What is the significance of roll diameter with reference to the roll separating force in rolling? 7M

**UNIT-IV**

7. a) Explain hydrostatic extrusion process with a neat sketch. 7M  
b) Explain in detail about the defects occurred in forging operations. 7M

**OR**

8. a) Differentiate between direct and indirect extrusion processes. 7M  
b) Explain with a neat sketch, the cold extrusion forging process. 7M

**UNIT-V**

9. a) Explain transfer moulding. Discuss its advantages and limitations. 7M  
b) Explain the Extrusion moulding process with a neat sketch. 7M

**OR**

10. a) Explain with a neat sketch about compression moulding and mention its advantages, disadvantages and applications. 7M  
b) Explain injection blow moulding process with a neat sketch. 7M

\*\*\*

Code: 7G532

II B.Tech. I Semester Supplementary Examinations May 2019

**Metallurgy and Material Science**

( Mechanical Engineering )

Max. Marks: 70

Time: 3 Hours

Answer all five units by choosing one question from each unit ( 5 x 14 = 70 Marks )

\*\*\*\*\*

**UNIT-I**

1. a) State Hume-Rothery's rules for the formation of substitutional solid solutions.  
b) Differentiate metal and alloy.

**OR**

2. How do you determine the grain size? And explain any two methods of determination of grain size.

**UNIT-II**

3. Draw Fe-Fe<sub>3</sub>C phase diagram and explain the phase transformation reactions in the diagram.

**OR**

4. Explain the relationship between equilibrium diagrams and properties of alloys.

**UNIT-III**

5. Differentiate between white cast iron and malleable cast iron.

**OR**

6. Give the classification of steels and explain the properties and uses of spheroidal cast iron

**UNIT-IV**

7. a) What is hardenability and how it is measured?  
b) Differentiate between Hardening and Tempering

**OR**

8. Describe briefly the following processes of surface hardening.  
(a) Flame hardening.  
(b) Induction hardening.

**UNIT-V**

9. What is reinforced composite? Explain the preparation of any one reinforced composite and also list its applications in the industry.

**OR**

10. Explain the following methods of manufacturing of steel  
(a) Open Hearth process  
(b) Electric furnace process

\*\*\*



**Code: 7G531**

II B.Tech. I Semester Supplementary Examinations May 2019

**Mechanics of Solids**  
( Mechanical Engineering )

Max. Marks: 70

Time: 3 Hours

Answer all five units by choosing one question from each unit ( 5 x 14 = 70 Marks )

\*\*\*\*\*

**UNIT-I**

1. a) A 40mm cubical block is subjected to shear stress and it is observed that  $\epsilon = 240 \text{ N/mm}^2$ . If shear modulus  $G = 84 \text{ kN/mm}^2$ , determine
- (i) the modulus of resilience,
  - (ii) the shear strain at elastic limit and
- The total strain energy absorbed at elastic limit?

8M

- b) Two aluminum strips are rigidly fixed to a steel strip of section 25 mm x 8 mm and 1m long. The aluminum strips are 0.5 m long each with section 25 mm x 5 mm. the composite bar is subjected to a tensile force of 10 kN as shown in fig.a. Determine the deflection of point of point B.  $E_s = E_a = 210 \text{ kN/mm}^2$

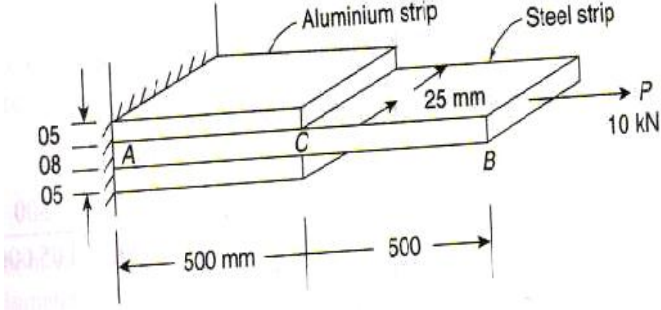

Fig a

6M

**OR**

2. a) A steel wire rope of a diameter of 10 mm is used for hoisting purpose during construction of a building. If a 50 m long wire rope is hanging vertically and 1kN load is being lifted at lower end of the wire determine the total extension of wire. Given the specific weight of the rope  $= 0.06 \text{ N/cm}^3$  and  $E = 200 \text{ kN/mm}^2$ ?
- b) Define and explain the differences between the resilience and toughness briefly?

10M

4M

**UNIT-II**

3. a) What do you understand by the positive and negative shear force?
- b) Draw the shear force and bending moment diagrams for the beam shown in fig.b?

4M

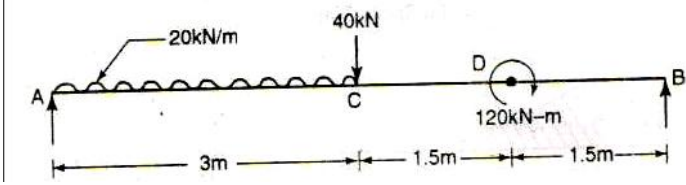

Fig b.

10M

**OR**

4. a) Draw the SFD and BMD for the overhanging beam shown in fig.c indicate the significant values including point of contra flexure?

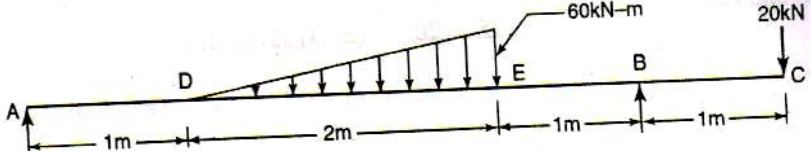
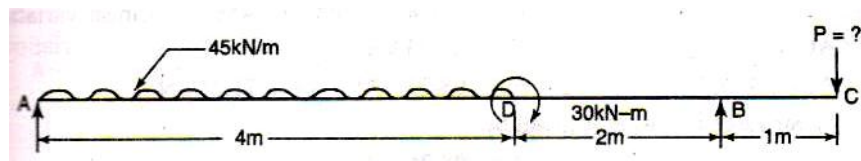

Fig c

7M

- b) For the beam AC shown in fig.d, determine the magnitudes of load P acting at C, such that the reaction at supports A & B are equal?



figd

7M

**UNIT-III**

5. a) A CI beam of unequal I-section with top flange 150 mm x 10 mm, bottom flange 200 mm x 15 mm and web 275 mm x 10 mm is supported as a cantilever of length 3 m. What load can be applied at the free end of the cantilever if the tensile stress in the section is limited to 80 N/mm<sup>2</sup>, the top flange of the beam comes under tension? 7M
- b) Define the modulus of rupture and state its significance? 7M

**OR**

6. a) A wooden beam of rectangular section 15 cm x 30 cm is simply supported over a length of 4 m. It carries a UDL of 4kN/m throughout its length. What is the maximum shear stress developed in the beam section? 7M
- b) A beam is of a circular section of diameter 80 mm. At particular section SF is 40kN. Draw the shear stress distribution along the depth of the section? 7M

**UNIT-IV**

7. a) An ISBM 150 rolled steel section is held as a cantilever of length 2 m. A weight of 200 N is dropped at the free end of the cantilever producing an instantaneous stress of 90 N/mm<sup>2</sup>. Calculate height from which the weight was dropped and the maximum instantaneous deflection in the cantilever.  $I = 726.4 \times 10^{-8} \text{ m}^4$ ,  $E = 200 \text{ GPa}$  7M
- b) A beam ABCD, 7m long hinged at A and roller supported at D carries 7kN load at B and 4 kN/m UDL over BC= 3m. If  $EI = 14,000 \text{ kNm}^2$  for the beam, determine the slope at A and deflection at point C. 7M

**OR**

8. a) An I section steel girder with  $I_{xx} = 2,502 \times 10^4 \text{ mm}^4$  is used as a beam for a span length of 4 m. The beam carries a UDL of 4 kN/m throughout its length. Determine the maximum deflection in the beam and slope at the end of the beam? 10M
- b) Derive the relationship between the bending moment and curvature in deflection of beams? 4M

**UNIT-V**

9. a) State the scientific reason why cylinders burst along longitudinal direction when they subjected to high pressure? 3M
- b) A thin cylindrical shell made of 5 mm thick steel plate is filled with water under pressure of 3 N/mm<sup>2</sup>. The internal diameter of the cylinder is 200 mm and its length is 1m. Determine the additional volume of the water pumped inside the cylinder to develop the required pressure. Take for steel  $E = 208 \text{ kN/mm}^2$  and  $1/m = 0.3$  and for water  $K = 2,200 \text{ N/mm}^2$ ? 11M

**OR**

10. a) A compound cylinder is made by shrinking one cylinder over another such that the outer diameter is 200 mm, the inner diameter is 100 mm and the junction diameter is 150 mm. If the junction pressure developed between the two cylinders is 10 N/mm<sup>2</sup> and the internal pressure is 50N/mm<sup>2</sup>, what are the hoop stresses at inner and outer radii of both the cylinders? 7M
- b) For what length of a CI column of 80 mm in diameter, the Euler's theory is applicable, if  $c = 550 \text{ N/mm}^2$  for CI and  $E = 102 \text{ kN/mm}^2$ , the column is hinged at both the ends? 7M

\*\*\*



Hall Ticket Number :										
----------------------	--	--	--	--	--	--	--	--	--	--

<b>R-17</b>
-------------

**Code: 7GC32**

II B.Tech. I Semester Supplementary Examinations May 2019

**Engineering Mathematics – III**

( Common to All Branches )

Max. Marks: 70

Time: 3 Hours

Answer all five units by choosing one question from each unit ( 5 x 14 = 70 Marks )

\*\*\*\*\*

<b>UNIT-I</b>
---------------

- Find a real root of the equation  $x^3 - 2x - 5 = 0$  using bisection method correct to three decimal places. 7M
  - Find the real root of the equation  $\sin^2 x + 1 = x^2$  using Newton-Raphson method. 7M

**OR**

- Employ Euler's method to obtain the approximate value of  $y$  at  $x = 1.0$  for the differential equation  $\frac{dy}{dx} = x - y^2$ ,  $y(0) = 1$ . 7M
  - Apply Runge-Kutta method of order 4, compute  $y(0.2)$  and  $y(0.4)$  from the equation  $\frac{dy}{dx} = x + y$ ,  $y(0) = 1$ . 7M

<b>UNIT-II</b>
----------------

- The population of a town in the decennial census was given below

Year : $x$	1891	1901	1911	1921	1931
Population: $y$ (in thousands)	46	66	81	93	101

Estimate the population for the year 1925. 7M

- Use Lagrange's interpolation formula to find the value of  $y$  when  $x = 3.5$  from the following table

$x$	0	1	3	4
$y$	-12	0	12	24

7M

**OR**

- Find the first and second derivatives of the function tabulated below at the point  $x = 1.5$

$x$	1.5	2.0	2.5	3.0	4.0
$y$	3.375	7.0	13.625	38.875	59

7M

- Evaluate  $\int_0^1 \frac{dx}{1+x^2}$  by using

(i) Trapezoidal rule (ii) Simpson's  $\frac{1}{3}$  rule and (iii) Simpson's  $\frac{3}{8}$  rule with  $h = 0.5$  and  $0.125$

7M

## UNIT-III

5. a) Determine the values of  $a$  and  $b$  by the method of least squares such that  $y = ae^{bx}$  fits the following data

$x$	2	4	6	8	10
$y$	4.077	11.084	30.128	81.897	222.62

7M

- b) Solve  $(p^2 + q^2)y = qz$  using Charpit's method.

7M

OR

6. a) Fit a second degree polynomial to the following data by the method of least squares

$x$	10	12	15	23	20
$y$	14	17	23	25	21

7M

- b) Using the method of separation of variables,

solve  $\frac{\partial u}{\partial x} = 4 \frac{\partial u}{\partial y}$ , when  $u(0, y) = 8e^{-3y}$

7M

## UNIT-IV

7. Prove that  $x^2 = \frac{f^2}{3} + 4 \sum_{n=1}^{\infty} (-1)^n \frac{\cos nx}{n^2}$ ,  $-f < x < f$  by using Fourier series and

hence show that  $\sum_{n=1}^{\infty} \frac{1}{n^2} = \frac{f^2}{6}$

14M

OR

8. Obtain a half range cosine series for  $f(x) = \begin{cases} kx, & 0 \leq x \leq l/2 \\ k(l-x), & l/2 \leq x \leq l \end{cases}$

and deduce the sum of the series is  $\frac{1}{1^2} + \frac{1}{3^2} + \frac{1}{5^2} + \dots = \frac{f^2}{8}$

14M

## UNIT-V

9. Find the Fourier sine and cosine transforms of  $e^{-ax}$  ( $a > 0$ ). Hence Evaluate the

integrals  $\int_0^{\infty} \frac{x \sin \} x}{x^2 + a^2} dx$  and  $\int_0^{\infty} \frac{\cos \} x}{x^2 + a^2} dx$

14M

OR

10. Obtain the Fourier sine transformation of

$$f(x) = \begin{cases} 4x, & \text{for } 0 < x < 1 \\ 4-x, & \text{for } 1 < x < 4 \\ 0, & \text{for } x > 4 \end{cases}$$

14M

\*\*\*

Hall Ticket Number :																			
----------------------	--	--	--	--	--	--	--	--	--	--	--	--	--	--	--	--	--	--	--

<b>R-17</b>
-------------

**Code: 7G533**

II B.Tech. I Semester Supplementary Examinations May 2019

**Basic Thermodynamics**

( Mechanical Engineering )

Max. Marks: 70

Time: 3 Hours

Answer all five units by choosing one question from each unit ( 5 x 14 = 70 Marks )

\*\*\*\*\*

<b>UNIT-I</b>
---------------

1. a) Explain quasi-static process. Explore its importance in Engineering. 7M
- b) An electric generator coupled to a windmill produces an average electrical power output of 5 kW. The power is used to charge a storage battery. Heat transfer from the battery to the surroundings occurs at a constant rate of 0.6 kW. Determine the total amount of energy stored in the battery, in kJ, in 8 hr. of operation. 7M

**OR**

2. a) Explain the terms state, path, process and cyclic process. 7M
- b) Explain working of constant volume gas thermometer with a neat diagram. 7M

<b>UNIT-II</b>
----------------

3. a) Derive steady flow energy equation. 7M
- b) A new scale N of temperature is divided in such a way that the freezing point of ice is 1000N and the boiling point is 4000N. What is the temperature reading on this new scale when the temperature is 1500C? At what temperature both the Celsius and the new scale reading would be the same? 7M

**OR**

4. a) State the Kelvin-Plank and Clausius statements of the second law of thermodynamics and establish equivalence between them. 7M
- b) State and prove Carnot Principle or Carnot theorem. 7M

<b>UNIT-III</b>
-----------------

5. a) A mass of air is initially at 2600C and 700 KPa and occupies 0.028m<sup>3</sup>. The air is expanded at constant pressure to 0.084m<sup>3</sup>. A Polytrophic process with n = 1.5 is then carried out, followed by a constant temperature process, which completes a cycle. All the processes are reversible i. Sketch the cycle in the P-v & T-s planes ii. Find heat received & rejected in the cycle iii. Find efficiency ( ) of the cycle. 7M
- b) What is the difference between ideal gas and a perfect gas? What is equation of state? 7M

**OR**

6. a) State Dalton's law of partial pressures. 7M
- b) 1 kg of air at 1.2 bar pressure and 18<sup>0</sup>C is compressed isentropically to 7 bars. Find the final temperature and the work done. If the air is cooled at the upper pressure to the original temperature of 18<sup>0</sup>C, what amount of heat is rejected and what further work of compression is done. 7M

UNIT-IV
---------

7. a) A blower handles 1 kg/sec of air at 20°C and consumes a power of 15 kW. The inlet and outlet velocities of air are 100 m/s and 150 m/s respectively. Find the exit air temperature, assuming adiabatic conditions. 7M
- b) Derive Clausius Clapeyron equation and explain its significance. 7M

OR

8. a) Write down the Vander Waal's equation of state. How does it differ from the ideal gas equation of state? 7M
- b) A mass of 0.25 kg of an ideal gas has a pressure of 300 kPa, a temperature of 80°C, and a volume of 0.07m<sup>3</sup>. The gas undergoes an irreversible adiabatic process to a final pressure of 300 kPa and a final volume of 0.1 m<sup>3</sup>, during which the work done on the gas is 25 kJ. Evaluate the specific heat at constant pressure and constant volume of the gas and the increase in entropy of the gas. 7M

UNIT-V
--------

9. a) Prove that heat and work are path functions. 7M
- b) Determine the power required to run a refrigerator that transfers 2000 KJ/min of heat from a cooled space at 0°C to the surrounding atmosphere at 27°C. The refrigerator operates on reversed Carnot cycle. 7M

OR

10. a) State the first law of thermodynamics and prove that for non-flow process it leads to  $Q=W+ U$ . 7M
- b) A spherical balloon holds 5 kg of air at 200 kPa and 450 K. If the air pressure inside is always proportional to the square of the balloon diameter, determine the work done when the balloon volume doubles due to heating. 7M

\*\*\*