

Hall Ticket Number :																			
----------------------	--	--	--	--	--	--	--	--	--	--	--	--	--	--	--	--	--	--	--

**R-15**

**Code: 5G245**

II B.Tech. II Semester Supplementary Examinations December 2017

**Electrical and Electronics Engineering**

( Mechanical Engineering )

Max. Marks: 70

Time: 3 Hours

Answer all five units by choosing one question from each unit ( 5 x 14 = 70 Marks )

\*\*\*\*\*

**UNIT-I**

1. a) How Kirchoff's voltage and current laws can be used to solve for circuit currents and voltages? Explain with suitable examples. 7M
- b) A delta connected capacitive network having capacitance of each arm  $10\mu\text{F}$  is to be transformed to an equivalent star network. What will be the capacitance value in the equivalent star network? 7M

**OR**

2. a) A resistance of  $10\ \Omega$  is connected in series with two resistances each of  $15\ \Omega$  arranged in parallel. What resistance must be shunted across the parallel combination so that the total current taken shall be 1.5 A with 20 V applied? 7M
- b) Derive the expression for equivalent inductance between any two points of a delta connected inductive network each arm having a pure inductance of value  $8\text{L Henry}$  7M

**UNIT-II**

3. a) What effect does the speed of a self-excited generator have on the buildup of voltage? Explain. 6M
- b) A dc shunt generator supplies a load at the voltage of 230V. The armature resistance of the generator is  $0.03\ \Omega$  and the field resistance is  $120\ \Omega$ . Determine the value of load current and load power when it generates an emf of 240V. The effect of armature reaction may be neglected. 8M

**OR**

4. a) Derive the expression of torque for a separately excited dc motor. 7M
- b) A 250V shunt motor on no load runs at 1000 rpm and takes 5A. The total armature and shunt field resistance are  $0.2\ \Omega$  and  $250\ \Omega$  respectively. Calculate the speed when loaded and taking a current of 50A, if the armature reaction weakens the field flux by 3%. 7M

**UNIT-III**

5. a) What information's are obtained from the open circuit test on a transformer? How is this test conducted? 6M
- b) A 20 kVA, single phase transformer of 1100/220V has an iron loss of 175W; the resistance of the primary winding is  $0.25\ \Omega$  and that of secondary is  $0.012\ \Omega$ . The corresponding leakage reactance's are  $1.1\ \Omega$  and  $0.055\ \Omega$  respectively. Calculate the percentage resistance and reactance drops at full load and power factor 0.8 lagging. At what percentage of full load will the efficiency be maximum? 8M

**OR**

6. a) What is synchronous impedance of alternator? How does it affect the voltage regulation of alternator? Explain with relevant circuit and phasor diagram. 7M
- b) A 4 pole, 50 Hz, three phase induction motor has a rotor resistance of  $0.02\ \Omega$  per phase and standstill reactance of  $0.5\ \Omega$  per phase. Determine the speed at which the maximum torque is developed. 7M

**UNIT-IV**

7. a) Explain how P-N junction diodes are specified and state the significance of each specifications. 6M
- b) Describe the working of a full wave bridge rectifier with circuit diagram and relevant waveforms. Derive the expression for average output voltage of the full wave rectifier. 8M

**OR**

8. a) Explain the working of a single stage common emitter practical amplifier. Derive an expression for amplifier gain. 7M
- b) Describe the similarities and dissimilarities in the operation of PNP and NPN transistors. 7M

**UNIT-V**

9. a) Explain two industrial applications of induction heating with block diagram. 6M
- b) Give a comparison between induction heating and dielectric heating. 8M

**OR**

10. a) Give the procedure for measurement of current and frequency using CRO. 6M
- b) Describe the function of Cathode Ray Tube (CRT) with schematic diagram. Explain how electric and magnetic deflections are controlled in CRO. 8M

\*\*\*

Hall Ticket Number :

--	--	--	--	--	--	--	--	--	--	--

**R-15**

**Code: 5GC43**

*II B.Tech. II Semester Regular Examinations May 2017*

**Environmental Science**

( Common to CE, ME & CSE)

Max. Marks: 70

Time: 3 Hours

Answer all five units by choosing one question from each unit ( 5 x 14 = 70 Marks )

\*\*\*\*\*

**UNIT-I**

1. a) Illustrate the scope & Importance of environmental studies 7M  
b) How does the declination of ecosystems occurs? 7M

**OR**

2. a) What is the scope and importance of environmental studies? 7M  
b) Describe the multidisciplinary nature of environmental studies. 7M

**UNIT-II**

3. a) Write about the applications of alternative energy resources 7M  
b) Write about the importance of natural resources 7M

**OR**

4. a) Distinguish between traditional agricultural and modern agricultural. 7M  
b) Summarize the effects of dams on forest and tribal people. 7M

**UNIT-III**

5. a) Write short note on sustainable development with examples. 7M  
b) Write short note on food chain and food web with examples. 7M

**OR**

6. a) What are the various threats leading to loss of biodiversity? 7M  
b) Discuss the various strategies of in-situ conservation of biodiversity 7M

**UNIT-IV**

7. a) How does the biodiversity is maintained ? 7M  
b) What are the various methods of control to reduce thermal pollution? 7M

**OR**

8. a) Explain about causes of marine pollution. 7M  
b) Explain about causes of noise pollution. 7M

**UNIT-V**

9. a) Explain about causes of air pollution. 7M  
b) What are the salient provisions of Wild life Act? 7M

**OR**

- 10 Explain the value of environment education and the role of women and environment. 14M

\*\*\*

Code: 5G542

II B.Tech. II Semester Supplementary Examinations December 2017

**Fluid Mechanics and Hydraulic Machinery**

( Mechanical Engineering )

Max. Marks: 70

Time: 3 Hours

Answer all five units by choosing one question from each unit ( 5 x 14 = 70 Marks )

\*\*\*\*\*

**UNIT-I**

1. a) Differentiate between :

- (i) Dynamic viscosity and kinematic viscosity
- (ii) Absolute and gauge pressure
- (iii) Simple and differential manometer
- (iv) Center of gravity and center of buoyancy.

6M

b) A 40 cm diameter pipe, conveying water, branches into two pipes of diameters 30 cm and 20 cm respectively. If the average velocity in the 40 cm diameter pipe is 3 m/s. Find the discharge in this pipe. Also determine the velocity in 20 cm pipe if the average velocity in 30 cm diameter pipe is 2 m/s.

8M

**OR**

2. a) A differential manometer is connected at two points A and B as shown in the figure. At B air pressure is  $7.848 \text{ N/cm}^2$  (abs.), find the absolute pressure at A.

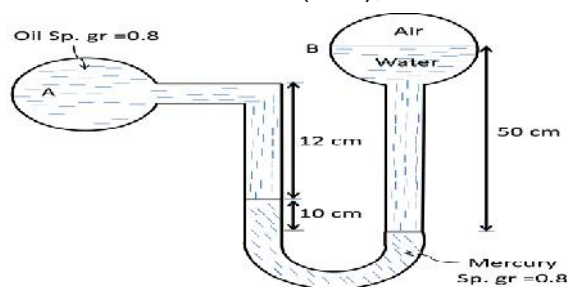

6M

b) Explain the terms:

- (i) Path line
- (ii) Streak line
- (iii) Stream line
- (iv) Stream tube

8M

**UNIT-II**

3. What is venturimeter? Derive an expression for discharge through through a venturimeter.

14M

**OR**

4. A pipe line carrying oil of specific gravity 0.87, changes in diameter from 200 mm diameter at a position A to 500 mm diameter at a position B which is 4 meters at a higher level. If the pressures at A and B are  $9.80 \text{ N/cm}^2$  and  $5.886 \text{ N/cm}^2$  respectively and the discharge is 200 liters/s. Determine the loss of head and the direction of flow.

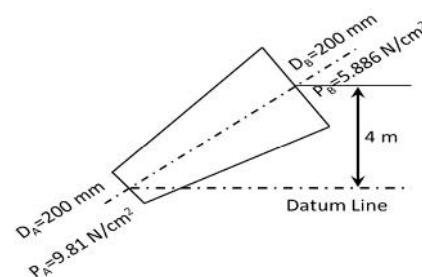

14M

<b>UNIT-III</b>
-----------------

5. A jet of water of diameter 100 mm strikes a curved plate at its center with a velocity of 15 m/s. The curved plate is moving with a velocity of 7 m/s in the direction of jet. The jet is deflected through an angle of  $150^\circ$ . Assuming the plate smooth find:”  
(i) force exerted on the plate in the direction of the jet, (ii) power of the jet, and  
(iii) efficiency. 14M

**OR**

6. Explain hydroelectric powerplant with neat sketch. 14M

<b>UNIT-IV</b>
----------------

7. a) Define the specific speed of a turbine. Derive an expression for the specific speed. What is the significance of specific speed? 6M
- b) Design a Pelton wheel for a head of 80 m and speed 300 r.p.m. The Pelton wheel develops 103 Kw S.P. Take  $C_v=0.98$ , speed ratio=0.45 and overall efficiency=0.80 8M

**OR**

- 8 a) Define the terms “unit power”, “unit speed” and “unit discharge” with reference to a hydraulic turbine .Also derive expressions for these terms. 6M
- b). A Kaplan turbine working under a head of 29 m develops 1287.5 KW S.P. If the speed ratio is equal to 2.1, flow ratio=0.62, diameter of boss=0.34 times the diameter of runner and overall efficiency of the turbine =89%, find the diameter of the runner and the speed of the turbine. 8M

<b>UNIT-V</b>
---------------

9. What is reciprocating pump? Describe the principle and working of a reciprocating pump with a neat sketch. Why is reciprocating pump not coupled directly to the motor? Discuss the reason in detail. 14M

**OR**

10. A centrifugal pump is running at 1000 r.p.m. The out let vane angle of the impeller is  $30^\circ$  and the velocity of flow at outlet is 3 m/s. The pump is working against a total head of 30 m and the discharge through the pump is  $0.3 \text{ m}^3/\text{s}$ . If the manometric efficiency of the pump is 75%, determine (i) the diameter of the impeller and (ii) the width of the impeller outlet. 14M

\*\*\*

Code: 5G543

II B.Tech. II Semester Supplementary Examinations December 2017

**Kinematics of Machinery**

( Mechanical Engineering )

Max. Marks: 70

Time: 3 Hours

Answer all five units by choosing one question from each unit ( 5 x 14 = 70 Marks )

\*\*\*\*\*

**UNIT-I**

1. a) Define the following
- (i) Link (iii) Kinematic pair
- (ii) Kinematic chain (iv) Inversion 4M
- b) Explain with a neat sketch Whitworth quick return motion mechanism 10M

**OR**

2. a) State and explain Grubler's criterion 4M
- b) Describes the various inversions of a single slider crank chain with sketches. 10M

**UNIT-II**

3. The crank of a slider crank mechanism is 480 mm long and rotates at 20 rad/sec in the counter clock wise direction. It has a connecting rod of 1600 mm long. Determine the following when the crank is at  $60^\circ$  from the inner dead centre,
- i) Velocity of the slider
- ii) Angular velocity of the connecting rod, and
- iii) The position and velocity of a point P on the connecting rod having least absolute velocity. 14M

**OR**

4. Locate the instantaneous centre of the mechanism shown in Fig. 4 and hence find the velocity of point 'C'.  $O_2A = 25$  mm,  $AB=BC=BO_4=75$  mm.

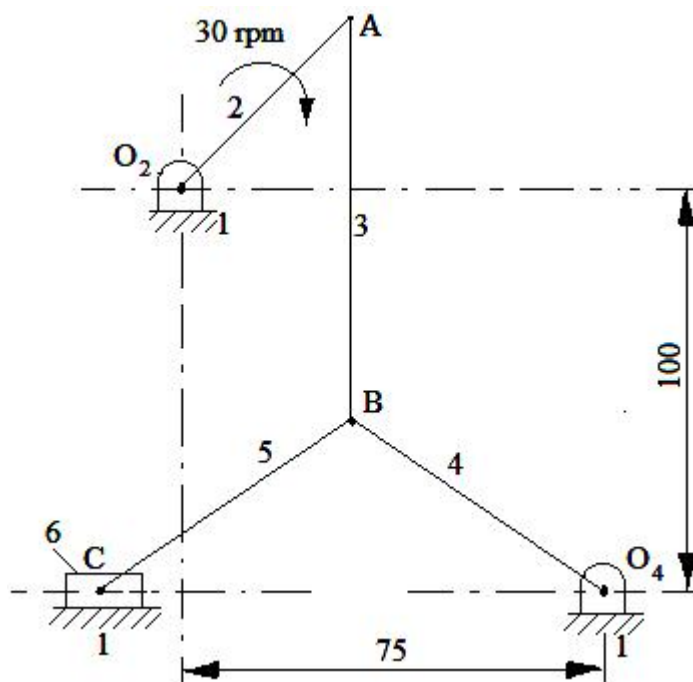

14M

UNIT-III
----------

5. Sketch the Hart's straight line motion mechanism and prove that the tracing point 'P' describes a straight line path. 14M

OR

6. Two shafts are connected by a Hook's joint. The power supplied to the driving shaft is 7.5 kW and the driving shaft rotates at uniform speed of 200 rpm. The angle between the axes of two shafts is  $18^\circ$ . If the output torque on the driven shaft is not to vary by more than 20% of the input torque, what is the necessary radius of gyration of the fly wheel of 40 Kg mass mounted on the driven shaft. 14M

UNIT-IV
---------

7. Two gears in mesh have a module of 8 mm and a pressure angle of  $20^\circ$ . The larger gear has 57 teeth while the pinion has 23 teeth. If the addenda on the pinion and gear wheel are equal to one module find,  
 i) The number of pairs of teeth in contact, and  
 ii) The angle of action of the pinion and gear wheel. 14M

OR

8. In an epicyclic gear train of sun and planet type, the pitch circle diameter of the annular wheel A is to be nearly equal to 220 mm and the module is 4 mm. when the annular wheel is stationary, the spider which carries 3 planet gears P of equal size has to make one revolution for every five revolutions of the driving spindle carrying sun wheel S.  
 Determine the number of teeth on all the wheels and also the exact diameter of the pitch circle of wheel A. 14M

UNIT-V
--------

9. From the following data draw the profile of a cam in which the follower moves with SHM during ascent while it moves with UADM during descent:  
 Least radius of cam = 50mm; Angle of ascent =  $48^\circ$ ,  
 Angle of descent =  $60^\circ$ ,  
 Angle of dwell between ascent and descent =  $42^\circ$ ;  
 Lift of follower = 40mm;  
 Dia of the roller = 30 mm;  
 Distance between line of action of the follower and axis of cam=20 mm. 14M

OR

10. The exhaust valve of a diesel engine has a lift of 31.4 mm. it is operated by a cam to give cycloidal motion during the opening and closing periods, each of which corresponds to  $60^\circ$  of cam rotation and dwell for the rest cam rotation. The follower is provided with a roller 10 mm radius and its line of stroke is radial. Draw the profile of the cam, if the minimum radius of the cam is 20 mm. determine the maximum velocity and acceleration of the follower during outward stroke for 2000 rpm. 14M

\*\*\*

Code: 5GC42

II B.Tech. II Semester Supplementary Examinations December 2017

**Probability and Statistics**

( Common to CE, ME &amp; IT)

Max. Marks: 70

Time: 3 Hours

Answer all five units by choosing one question from each unit ( 5 x 14 = 70 Marks )

\*\*\*\*\*

**UNIT-I**

1. a) Box A contains nine cards numbered 1 to 9 and box B contains five cards numbered 1 to 5. A box is chosen at random and a card is drawn, if the card shows an even number another card is drawn from the same box, if the card shows an odd number, a card is drawn from the other box.
- (i) What is the probability that the both cards show an even number?
- (ii) If both cards show even number, what is the probability that they come from box A.
- (iii) What is the probability that both cards are odd? 7M
- b) i. If A and B are independent events. Then prove that  $A^c$  and  $B^c$  are also independent events.
- ii. If A and B are independent events. Then show that A and  $B^c$  are also independent events 7M

**OR**

2. a) If X is a continuous random variable and  $y = ax + b$ , prove that  $E(y) = a E(X) + b$  and  $V(y) = a^2 V(x)$  7M
- b) A continuous random variable is given by  $f(x) = \begin{cases} k(1-x^2), 0 < x < 1 \\ 0, otherwise \end{cases}$ .
- Find i) k, ii) mean iii) variance. 7M

**UNIT-II**

3. a) Explain the properties and importance of Normal Distribution. 7M
- b) If a poisson distribution is such that  $P(x=1) = \frac{3}{2} P(x=3)$ . Find
- (i)  $P(x=1)$  (ii)  $P(x=3)$  (iii)  $P(2 < x < 5)$  7M

**OR**

4. In a Normal distribution 31% of the items are under 45 and 8% are 64. Find the mean and standard deviation of the distribution. 14M

**UNIT-III**

5. A population consists of 5, 10, 14, 18, 13, 24. Consider all possible samples of size 2 which can be drawn without replacement from the population. Find
- i. The mean of the population
- ii. The standard deviation of the population
- iii. The mean of the sampling distribution of means
- The standard deviation of sampling distributions of means. 14M

**OR**

6. a) Find 95% confidence limits for the mean of a normality distributed population from which the following sample was taken 15,17,10,18,16,9,7,11,13,14. 7M
- b) What is the maximum error one can expect to make with probability 0.90 when using the mean of a random sample of size  $n=64$  to estimate the mean of population with variance 2.56. 7M

## UNIT-IV

7. a) A sample of 64 students have a mean weight of 70 kgs. Can this be regarded as a sample from a population with mean weight 56 kgs and standard deviation 25 kgs. 7M
- b) Random samples of 400 men and 600 women were asked whether they would like to have a flyover near their residence. 200 men and 325 women were in favor of the proposal. Test the hypothesis that proportions of men and women in favor of the proposal are same, at 5% level. 7M

OR

8. a) Experience had shown that 20% of a manufactured product is of the top quality. In one day, production of 400 articles only 50 are of top quality. Test the hypothesis at 0.05 level. 7M
- b) In a study on the influence of habitation, the intelligent quotients (IQs) of 16 students from urban area was found to have a mean of 107 and standard deviation of 10, while the IQs of 14 students from a rural area showed a mean of 112 and standard deviation of 8. Determine whether the IQs differ significantly at 0.05 level. 7M

## UNIT-V

9. From the following data find whether there is any significant liking in the habit of taking soft drinks among the categories of the employees.

Soft drinks	Clerks	Teachers	Officers
Pepsi	10	25	65
Thumsup	15	30	65
Fanta	50	60	30

14M

OR

10. Fit a poisson distribution and test the goodness of it for the following data.

X	0	1	2	3	4
f(x)	109	65	22	3	1

14M

\*\*\*



Code: 5G541

II B.Tech. II Semester Supplementary Examinations December 2017

**Applied Thermodynamics-I**

( Mechanical Engineering )

Max. Marks: 70

Time: 3 Hours

Answer all five units by choosing one question from each unit ( 5 x 14 = 70 Marks )

\*\*\*\*\*

**UNIT-I**

1. a) Why does an air standard cycle differ from an actual cycle? Explain it with neat sketches? 7M
- b) Write short notes on (i) Air Injection System, (ii) Battery Ignition System and (iii) Mist Lubrication System 7M

**OR**

2. a) What is the fundamental principle of working of an IC engine? Elaborate it with neat diagrams. 5M
- b) Write short notes on (i) Solid Injection System, (ii) Magneto Ignition system and (iii) Wet sump Lubrication System 9M

**UNIT-II**

3. a) Elaborate the differences between normal and abnormal combustion? Explain it with one or two parameters. 8M
- b) Write notes on (i) knocking, (ii) fuel rating and (iii) anti-knock additives 6M

**OR**

4. a) Elaborate the four stages of combustion in a C.I. engine. 8M
- b) What do you mean by (i) Diesel Knock, (ii) Delay period, (iii) effect of engine variable 6M

**UNIT-III**

5. a) Explain the performance of an engine with necessary parameters and diagrams 7M
- b) Derive the fundamental equations for brake power and specific fuel consumption. 7M

**OR**

6. a) Derive the basic performance parameters such as mechanical efficiency, mean effective pressure and torque, volumetric efficiency, thermal efficiency and specific fuel consumption. 8M
- b) How do you determine frictional losses and indicated horse power? 6M

**UNIT-IV**

7. a) What do power producing and power absorbing machines differ? Explain them with neat sketches 6M
- b) Derive the work required by a reciprocating compressor. 8M

**OR**

8. a) What is meant by positive displacement? Derive the condition for minimum work? 8M
- b) Write short notes on (i) rotor dynamic machinery (ii) effect of clearance and (iii) under cooling 6M

**UNIT-V**

9. a) Explain the working principle of a centrifugal compressor? Show its velocity and pressure variation. 8M
- b) What do you mean by (i) pressure coefficient and adiabatic coefficient (ii) slip factor and (iii) velocity diagram 6M

**OR**

10. a) How does an axial flow compressor work? Explain its velocity triangles. 8M
- b) Write notes on (i) degree of reaction, (ii) isentropic efficiency (iii) polytropic efficiency 6M

\*\*\*