

--	--	--	--	--	--	--	--	--	--

Code: 5G541

II B.Tech. II Semester Supplementary Examinations Nov/Dec 2018

**Applied Thermodynamics-I**

( Mechanical Engineering )

Max. Marks: 70

Time: 3 Hours

Answer all five units by choosing one question from each unit ( 5 x 14 = 70 Marks )

\*\*\*\*\*

**UNIT-I**

1. a) Classify I.C engines in detail.
- b) List out the differences between S.I. Engine and C.I. Engine.

**OR**

2. a) Describe the optimum opening position of exhaust valve to reduce the exhaust blow down loss in S I Engine.
- b) Explain the working of Simple Carburetor with neat sketch.

**UNIT-II**

3. a) Bring out clearly the various stages of combustion in CI Engine and explain.
- b) List out different parameters that influence ignition delay during combustion process in C.I engine and explain any two parameters.

**OR**

4. a) What is Cetane number? Explain how CI engine fuels are rated.
- b) With the help of a neat diagram explain the working principle of indirect injection combustion chamber of a C.I. engine.

**UNIT-III**

5. a) What is the significance of conducting the Morse test? Explain in detail.
- b) The following data was recorded during testing of a four stroke cycle gas engine. Area of indicator diagram = 900 mm<sup>2</sup> ; Length of indicator diagram = 70 mm; spring scale = 0.3 bar/mm; Diameter of piston = 200 mm; Length of stroke = 250 mm; Speed = 300 rpm; Determine i) Indicated mean effective pressure ii) Indicated power.

**OR**

6. a) A gasoline engine working on four stroke develops a brake power of 20.9 kW. A Morse test was conducted on this engine and the brake power (kW) obtained when each cylinder was made inoperative by short circuiting the spark plug are 14.9, 14.3, 14.8 and 14.5 respectively. The test was conducted at constant speed. Find i) indicator power, ii) mechanical efficiency and iii) bmep when all the cylinders are firing. The bore of the engine is 75 mm and the stroke is 90 mm. The engine is running at 3000 rpm.
- b) Define the terms i) Specific fuel consumption ii) mean effective pressure.

**UNIT-IV**

7. a) What is an air compressor? List out the applications where compressed air is used.
- b) A single stage single acting reciprocating air compressor with 0.3 m bore and 0.4 m stroke runs at 400 rpm. The suction pressure is 1 bar at 300 K and the delivery pressure is 5 bar. Find the power required to run it, if the compression is isothermal, adiabatic and compression follow  $p v^{1.3} = C$ . Also find the isothermal efficiency.

**OR**

8. a) Derive the expression for the volumetric efficiency of a reciprocating air compressor in terms of clearance ratio, pressure ratio and index of the compression.
- b) A rotary air compressor compresses 100 kg of air/minute from 1.2 bar and 293 K to 4.8 bar. Find the power required to drive the compressor, if the compression is isentropic and follows  $p v^{1.3} = \text{constant}$ .

**UNIT-V**

9. a) Explain, with a neat sketch, the working of a centrifugal compressor and obtain an expression for the work done.
  - b) Describe the terms slip factor and power input factor in centrifugal compressors.
- OR**
10. a) 20 m<sup>3</sup> of air per second at 1 bar 15°C is to be compressed in a centrifugal compressor through a pressure ratio of 1.5:1. The compression follows the law  $P V^{1.5} = \text{constant}$ . The velocity of flow at inlet and outlet remains constant and is equal to 60 m/s. If the inlet and outlet impeller diameters are 0.6 m and 1.2 m respectively and rotates at a speed of 5000 rpm. Find (i) the blade angles at inlet and outlet of the impeller, and the angle at which the air from the impeller enters the casing; (ii) breadth of impeller blade at inlet and outlet.
  - b) Discuss on Isentropic efficiency of Centrifugal compressor.

\*\*\*

**Code: 5G245**

II B.Tech. II Semester Supplementary Examinations Nov/Dec 2018

**Electrical and Electronics Engineering**

( Mechanical Engineering)

Max. Marks: 70

Time: 3 Hours

Answer all five units by choosing one question from each unit ( 5 x 14 = 70 Marks )

\*\*\*\*\*

**UNIT-I**

1. a) For the arrangement shown in Figure, find (i) the equivalent circuit capacitance and (ii) the voltage across a 4.5 μF capacitor.

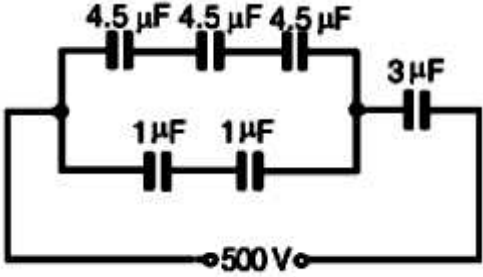

- b) A 35 V d.c supply is connected across a resistance of 600 Ω in series with an unknown resistance R. A voltmeter having a resistance 1200 Ω is connected across 600 Ω and shows a reading of 5V. Calculate the value of resistance R.

**OR**

2. a) Define the following terms with an example: (i) Unilateral elements (ii) Distributed elements (iii) Linear elements (iv) active elements
- b) In the given circuit shown in figure1, find the value of the resistance R and the current through it, when the branch AD carries no current.

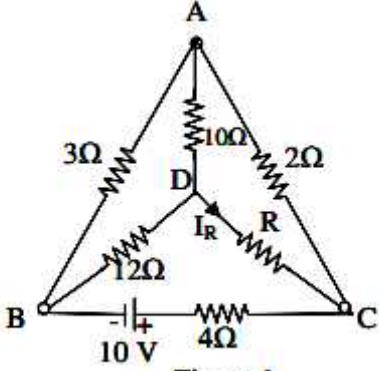

Figure 1

**UNIT-II**

3. a) Draw the neat sketch of a 3-point starter and explain its working?
- b) A 4 pole wave wound dc generator is having 50 slots with 20 conductors per slot and rotating at 1500 rpm. The flux per pole is 0.018 wb, calculate the emf generated

**OR**

4. a) Briefly explain the procedure to conduct Swinburne's test on a DC machine?
- b) A 6-pole generator has a lap-wound armature with 40 slots with 20 conductors per slot. The flux per pole is 25 mWb. Calculate the speed at which the machine must be driven to generate an e.m.f. of 300 V.

**UNIT-III**

5. a) Derive EMF equation of a single phase transformer?  
b) A 100KVA, 3KV, 50Hz, 3-phase star connected alternator has effective armature resistance of  $0.2 \Omega$ . The field current of 20Amps produces SC current of 120 Amps and OC volts of 1060V (line value). Calculate the full load voltage regulation at 0.5 p.f. lag

**OR**

6. a) Explain the procedure to find the regulation of three phase alternator by using synchronous impedance method?  
b) A 3-phase, 60 Hz induction motor has 2 poles. If the slip is 2% at a certain load, determine (i) the synchronous speed, (ii) the speed of the rotor and (iii) the frequency of the induced e.m.f.'s in the rotor.

**UNIT-IV**

7. a) Draw and explain the circuit diagram of a common emitter amplifier and draw its characteristics?  
b) Discuss about the differences between half wave rectifier and full wave rectifier by using the output waveforms?

**OR**

8. a) Compare the characteristics of transistor amplifier in the three configurations?  
b) A transistor having  $\beta = 0.96$  is placed in common based configuration with load resistance of  $5k \Omega$  if the emitter to base junction resistance is  $80 \Omega$ , find the values of amplifier current voltage and power gain

**UNIT-V**

9. a) Explain the principle of dielectric heating. Also write the applications of Dielectric heating.  
b) Discuss in detail the applications of CRO?

**OR**

10. a) Draw the block diagram of vertical amplifier used in CRO and explain its operation.  
b) Explain how lissajous figures can be used in frequency measurement

\*\*\*

Hall Ticket Number :

--	--	--	--	--	--	--	--	--	--	--

**R-15**

**Code: 5GC43**

II B.Tech. II Semester Supplementary Examinations Nov/Dec 2018

**Environmental Science**

( Common to CE, ME and CSE )

Max. Marks: 70

Time: 3 Hours

Answer *all five* units by choosing one question from each unit ( 5 x 14 = 70 Marks )

\*\*\*\*\*

**UNIT-I**

1. a) Explain the role of individual in protecting the environment 7M  
b) Explain hydrosphere, lithosphere in detail. 7M

**OR**

2. a) Write about major environmental problems of world. 7M  
b) Explain Bhopal gas tragedy in detail 7M

**UNIT-II**

3. a) Explain any two case studies on dams and mines over exploitation 7M  
b) Explain hydrological cycle in detail. 7M

**OR**

4. a) Explain definition and impacts of soil erosion. 7M  
b) Explain various applications of any two renewable energy resources. 7M

**UNIT-III**

5. a) Explain ecological pyramids with examples. 7M  
b) Explain energy flow in eco system in detail. 7M

**OR**

6. a) Write a short note on habitat loss and poaching of wild life. 7M  
b) Explain in situ conservation strategies in detail. 7M

**UNIT-IV**

7. a) Write in detail about sources and effects of water pollution. 7M  
b) Explain nuclear pollution in detail. 7M

**OR**

8. a) Write about sources and impacts of improper solid waste management. 7M  
b) Write a short note on incineration and sanitary land filling. 7M

**UNIT-V**

9. a) Explain ozone layer depletion in detail. 7M  
b) Write about various methods of waste land reclamation. 7M

**OR**

10. a) Write in detail about family welfare programmes. 7M  
b) Write a note on environment and human health. 7M

\*\*\*

Hall Ticket Number :										
----------------------	--	--	--	--	--	--	--	--	--	--

<b>R-15</b>
-------------

**Code: 5G542**

II B.Tech. II Semester Supplementary Examinations Nov/Dec 2018

**Fluid Mechanics and Hydraulic Machinery**

( Mechanical Engineering )

Max. Marks: 70

Time: 3 Hours

Answer all five units by choosing one question from each unit ( 5 x 14 = 70 Marks )

\*\*\*\*\*

<b>UNIT-I</b>
---------------

1. a) Define surface tension and derive the relationship between surface tension and pressure inside a droplet of liquid. 7M
- b) Calculate the capillary rise in a glass tube of 2.5 mm diameter when immersed vertically in (i) water and (ii) mercury. Take surface tensions = 0.0725 N/m for water and = 0.52 N/m for mercury in contact with air. The specific gravity for mercury is given as 13.6 and angle of contact =  $130^\circ$ . 7M

**OR**

2. a) State law of conservation of mass and derive the continuity equation for one dimensional fluid flows and also define the terms (i) stream line (ii) path line (iii) streak line and (iv) stream tube 10M
- b) The following case represent the two velocity components, determine the third component of velocity such that they satisfy the continuity equation 4 M
- i)  $u = x^2 + y^2 + z^2$  ;  $v = xy^2 + xy - yz^2$ .

<b>UNIT-II</b>
----------------

3. a) Derive Euler's equation of motion for one dimensional flow of incompressible fluid and obtain Bernoulli's equation. 7M
- b) A bend  $45^\circ$  of a rectangular air duct  $1 \text{ m}^2$  cross sectional area is gradually reduced to  $0.5 \text{ m}^2$  area. Find the magnitude and direction of force required to hold the duct in position, if the velocity of flow at  $1 \text{ m}^2$  section is 10 m/s with a pressure of  $2.943 \text{ N/cm}^2$ , density of air may be taken as  $1.16 \text{ kg/m}^3$  7M

**OR**

4. a) List out the major and minor losses occurred in the flow through pipes and give the magnitudes of each. 7M
- b) A Venturimeter has its axis vertical, the inlet and throat diameters being 150 mm and 75 mm respectively. The throat is 2.25 m above inlet and venture constant = 0.96. Petrol of specific gravity 0.78 flows up through the meter at a rate of  $0.029 \text{ m}^3/\text{s}$ . Find the pressure difference between inlet and throat. 7M

<b>UNIT-III</b>
-----------------

5. a) Draw a simplified sketch of Hydro electric power plant and discuss the importance of each component in it. 7M
- b) A jet of water having a velocity of 40 m/s strikes a curved vane, which is moving with a velocity of 20 m/s. The jet makes an angle of  $30^\circ$  with the direction of motion of vane at inlet and leaves at an angle of  $90^\circ$  to the direction of motion of vane at outlet. Draw the velocity triangles at inlet and outlet and determine the vane angles at inlet and outlet so that the water enters and leaves the vane without shock. 7M

**OR**

6. a) Derive the expressions for the force exerted by a jet of water on flat stationary vertical and inclined plates. 7M
- b) A 50 mm diameter jet having a velocity of 25 m/s, strikes a flat plate, the normal of which is inclined at  $30^\circ$  to the axis of the jet. Calculate the normal force exerted on the plate (i) when the plane is stationary (ii) when the plate is moving with a velocity of 10 m/s in the direction of the jet. Also, find the work done and the efficiency of the jet when the plate is moving. 7M

<b>UNIT-IV</b>
----------------

7. a) Classify hydraulic turbines in detail. 7M
- b) A Pelton wheel has a mean bucket speed of 12 m/s and is supplied with water at a rate of 750 litres/sec under a head of 35 m. If the bucket deflects the jet through an angle of  $160^\circ$ , find the power developed by the turbine and its hydraulic efficiency. Take the coefficient velocity as 0.98. Neglect friction in the bucket. Also determine the overall efficiency of the turbine if its mechanical efficiency is 80 %. 7M

**OR**

8. a) Derive the expression for specific speed of a Hydraulic turbine. 7M
- b) A turbine is to operate under a head of 25 m at 200 r.p.m. The discharge is  $9 \text{ m}^3/\text{sec}$ . If the efficiency is 90%, determine the performance of the turbine under a head of 20 meters. 7M

<b>UNIT-V</b>
---------------

9. a) Briefly explain the working of Centrifugal pump with help of a neat sketch. 7M
- b) A single stage centrifugal pump with impeller diameter of 30 cm rotates at 2000 r.p.m. and lifts  $3 \text{ m}^3$  of water per sec to a height of 30 m with an efficiency of 75%. Find the number of stages and diameter of each impeller of a similar multistage pump to lift  $5 \text{ m}^3$  of water per sec to a height of 200 m when running at 1500 r.p.m 7M

**OR**

10. a) Explain with a neat sketch working principle of a reciprocating pump. 7M
- b) A single acting reciprocating pump has a plunger of diameter 250 mm and stroke of 350 mm. If the speed of pump is 60 r.p.m. and it delivers 16.5 litres/sec of water against a suction head of 5 m and delivery head of 20m, find the theoretical discharge, coefficient of discharge, slip, percentage of slip and the power required to drive the pump. 7M

\*\*\*

Code: 5G543

II B.Tech. II Semester Supplementary Examinations Nov/Dec 2018

**Kinematics of Machinery**

( Mechanical Engineering )

Max. Marks: 70

Time: 3 Hours

Answer all five units by choosing one question from each unit ( 5 x 14 = 70 Marks )

\*\*\*\*\*

**UNIT-I**

1. a) Define kinematic pair. How kinematic pairs are classified? Explain with neat sketches. 8M
- b) Differentiate between
- (i) Binary joint and binary link
  - (ii) Mechanism and machine
  - (iii) Completely constrained motion and incompletely constrained motion 6M

**OR**

2. What do you mean by inversion of mechanism? Explain with sketches all inversions of single slider crank chain. 14M

**UNIT-II**

3. The following data refer to a crank and slotted lever type quick return mechanism shown in figure.

OA = 400 mm, OP = 200 mm, AR = 700 mm, RS = 300 mm.

If the crank OP rotates at 210 rpm in clockwise direction and makes an angle AOP = 120°, determine the velocity of the cutting tool S and angular velocities of the link RS.

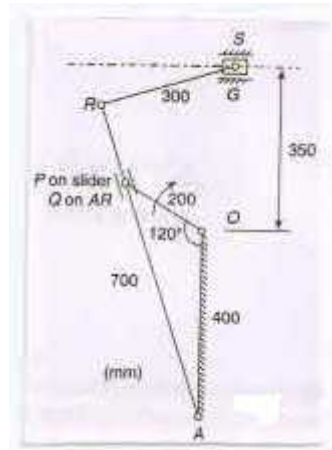

14M

**OR**

4. In a four-bar ABCD in which AD is fixed and is 20cm long. The crank AB is 6.25 cm long rotates in a clockwise direction at 95.5 r.p.m. The crank drives the link CD 11.25 cm long by means of connecting link BC 17.5 cm long. Draw the velocity diagram and acceleration diagram when angle BAD = 60° and B and C lies on the same side of AD. Determine the angular velocity and angular accelerations of CD and BC. 14M

**UNIT-III**

5. a) Describe Hart's mechanism with a neat sketch and prove that the tracing point describes a straight line path. 7M
- b) How can we ensure that a Tchebicheff mechanism traces an approximate straight line? 7M

**OR**

6. a) What is mean by steering gear? Write about Davis steering gear. 7M  
 b) Two shafts are connected by a Hooke's joint. The driving shaft is rotating at a uniform speed of 1000 r.p.m Find the greatest permissible angle between the axes of the two shafts so that the total fluctuation of speed does not exceed 100 r.p.m. 7M

**UNIT-IV**

7. a) Derive an expression for length of path of contact between two mating gears. 7M  
 b) Two mating gears have 50 and 13 involute teeth of module 10 mm and  $20^\circ$  pressure angle. The addendum is one module. Does the interference occur? If it occurs, to what value should the pressure angle be changed to eliminate interference? 7M

**OR**

8. An epicyclic gear train as shown in figure 1 is composed of a fixed annular wheel A having 150 teeth. Meshing with A is a wheel B which drives wheel D through an idle wheel C, D being concentric with A. Wheels B and C are carried on an arm which revolves clockwise at 100 r.p.m about the axis of A or D. If the wheels B and D are having 25 teeth and 40 teeth respectively, find the number of teeth of C and the speed and sense of rotation of C.

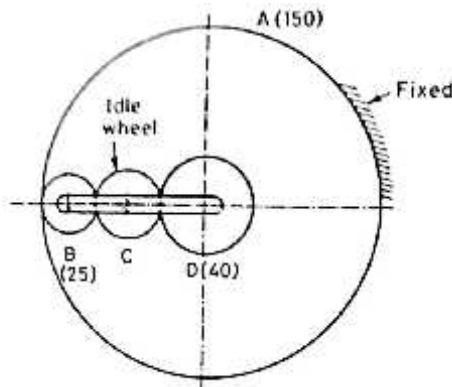

14M

**UNIT-V**

- 9 Draw the profile of a cam operating knife-edge follower from the following data:  
 (i) Follower to move outward through a distance of 30 mm during  $120^\circ$  of cam rotation  
 (ii) Follower to dwell for the next  $60^\circ$  of can rotation  
 (iii) Follower to return to its initial position during  $90^\circ$  of cam rotation  
 (iv) Follower to dwell for the remaining  $90^\circ$  of cam rotation.

The cam is rotating clockwise at uniform speed of 500 r.p.m. The minimum radius of the cam is 40 mm and the line of stroke of the follower is offset 15 mm from the axis of the cam and the displacement of the follower is to take place with uniform and equal acceleration and retardation on both the outward and return stroke.

14M

**OR**

- 10 Draw the profile of a cam to give the following motion to the reciprocating follower with a flat or mushroom contact surface:  
 (a) Follower to move outward through a distance of 30 mm during  $120^\circ$  of cam rotation  
 (b) Follower to dwell for  $30^\circ$  of cam rotation  
 (c) Follower to return to its initial position during  $120^\circ$  of cam rotation  
 (d) Follower to dwell for the remaining  $90^\circ$  of cam rotation.

The minimum radius of cam is 25 mm and the flat face of the follower is at right angles to the line of stroke of the follower. The outward and return strokes of the follower are take place with uniform acceleration and retardation motion.

14M

\*\*\*



**Code: 5GC42**

II B.Tech. II Semester Supplementary Examinations Nov/Dec 2018

**Probability and Statistics**

( Common to CE, ME and IT )

Max. Marks: 70

Time: 3 Hours

Answer all five units by choosing one question from each unit ( 5 x 14 = 70 Marks )

\*\*\*\*\*

**UNIT-I**

- 1. a) A box contains n tickets marked 1 through n. Two tickets are drawn in succession without replacement. Determine the probability that the number on the tickets are consecutive integers.

7M
- b) In a factory, machine A produces 40% of the output and machine B produces 60%. On the average, 9 items in 1000 produced by A are defective and 1 item in 250 produced by B is defective. An item drawn at random from a day's output is defective. What is the probability that it was produced by A or B?

7M

**OR**

- 2. a) A fair coin is tossed until a head or five tails occurs. Find the expected number E of tosses of the coin.

7M
- b) Calculate expectation and variance of X, if the probability distribution of the random variable X is given by

7M

X	-1	0	1	2	3
f	0.3	0.1	0.1	0.3	0.2

**UNIT-II**

- 3. a) Ten coins are thrown simultaneously. Find the probability of getting at least six heads.

7M
- b) Fit a Poisson distribution to the following data

7M

x	0	1	2	3	4	5	Total
f	142	156	69	27	5	1	400

**OR**

- 4. a) Find the mean and standard deviation of a normal distribution in which 7% of items are under 35 and 89% are under 63.

7M
- b) A sales tax officer has reported that the average sales of the 500 business that he has to deal with during a year is Rs. 36,000 with a standard deviation of 10,000. Assuming that the sales in these business are normally distributed, find the percentage of business the sales of which are likely to range between Rs. 30,000 and Rs. 40,000.

7M

**UNIT-III**

- 5. A population consists of six numbers 4, 8, 12, 16, 20, 24. Consider all samples of size two which can be drawn without replacement from this population. Find a) The population mean, b) The population standard deviation, c) The mean of the sampling distribution of means, d) The standard deviation of the sampling distribution of means.

14M

**OR**

- 6. a) The mean voltage of a battery is 15 and S.D is 0.2. Find the probability that four such batteries connected in series will have a combined voltage of 60.8 or more volts.

7M
- b) A sample of 10 cam shafts intended for use in gasoline engines has an average eccentricity of 1.02 and a standard deviation of 0.044 inch. Assuming the data may be treated a random sample from a normal population, determine a 95% confidence interval for the actual mean eccentricity of the cam shaft?

7M

## UNIT-IV

7. a) An oceanographer wants to check whether the depth of the ocean in a certain region is 57.4 fathoms, as had previously been recorded. What can he conclude at the 0.05 level of significance, if readings taken at 40 random locations in the given region yielded a mean of 59.1 fathoms with a standard deviation of 5.2 fathoms? 7M
- b) The mean life of a sample of 10 electric bulbs was found to be 1456 hours with S.D. of 423 hours. A second sample of 17 bulbs chosen from a different batch showed a mean life of 1280 hours with S.D. of 398 hours. Is there a significant difference between the means of two batches? 7M

OR

8. a) A manufacturer claimed that at least 95% of the equipment which he supplied to a factory conformed to specifications. An examination of a sample of 200 pieces of equipment revealed that 18 were faulty. Test his claim at 5% level of significance. 7M
- b) The mean life time of a sample of 25 fluorescent light bulbs produced by a company is computed to be 157 hours with a S.D. of 120 hours. The company claims that the average life of the bulbs produced by the company is 1600 hours using the level of significance of 0.05. Is the claim acceptable? 7M

## UNIT-V

9. a) The following random samples are measurements of the heat-producing capacity (in millions of calories per ton) of specimens of coal from two mines:

Mine 1:	8,260	8,130	8,350	8,070	8,340	---
Mine 2:	7,950	7,890	7,900	8,140	7,920	7,840

Use the 0.02 level of significance to test whether it is reasonable to assume that the variances of the two populations samples are equal. 7M

- b) A pair of dice are thrown 360 times and the frequency of each sum is indicated below:

Sum	2	3	4	5	6	7	8	9	10	11	12
Frequency	8	24	35	37	44	65	51	42	26	14	14

Would you say that the dice are fair on the basis of the Chi-square test at 0.05 level of significance? 7M

OR

10. a) An instructor has two classes A and B in a particular subject. Class A has 16 students while class B has 25 students. On the same examination, although there was no significant difference in mean grades, class A has a standard deviation of 9 while class B has a standard deviation of 12. Can conclude at the 0.01 level of significance that the variability of class B is greater than that of A? 7M
- b) A firm manufacturing rivets wants to limit variations in their length as much as possible. The lengths (in cms) of 10 rivets manufactured by a new process are

2.15	1.99	2.05	2.12	2.17
2.01	1.98	2.03	2.25	1.93

Examine whether the new process can be considered superior to the old if the old population has standard deviation 0.145 cm? 7M

\*\*\*